

siehe "Blatt 1"
see "page 1"

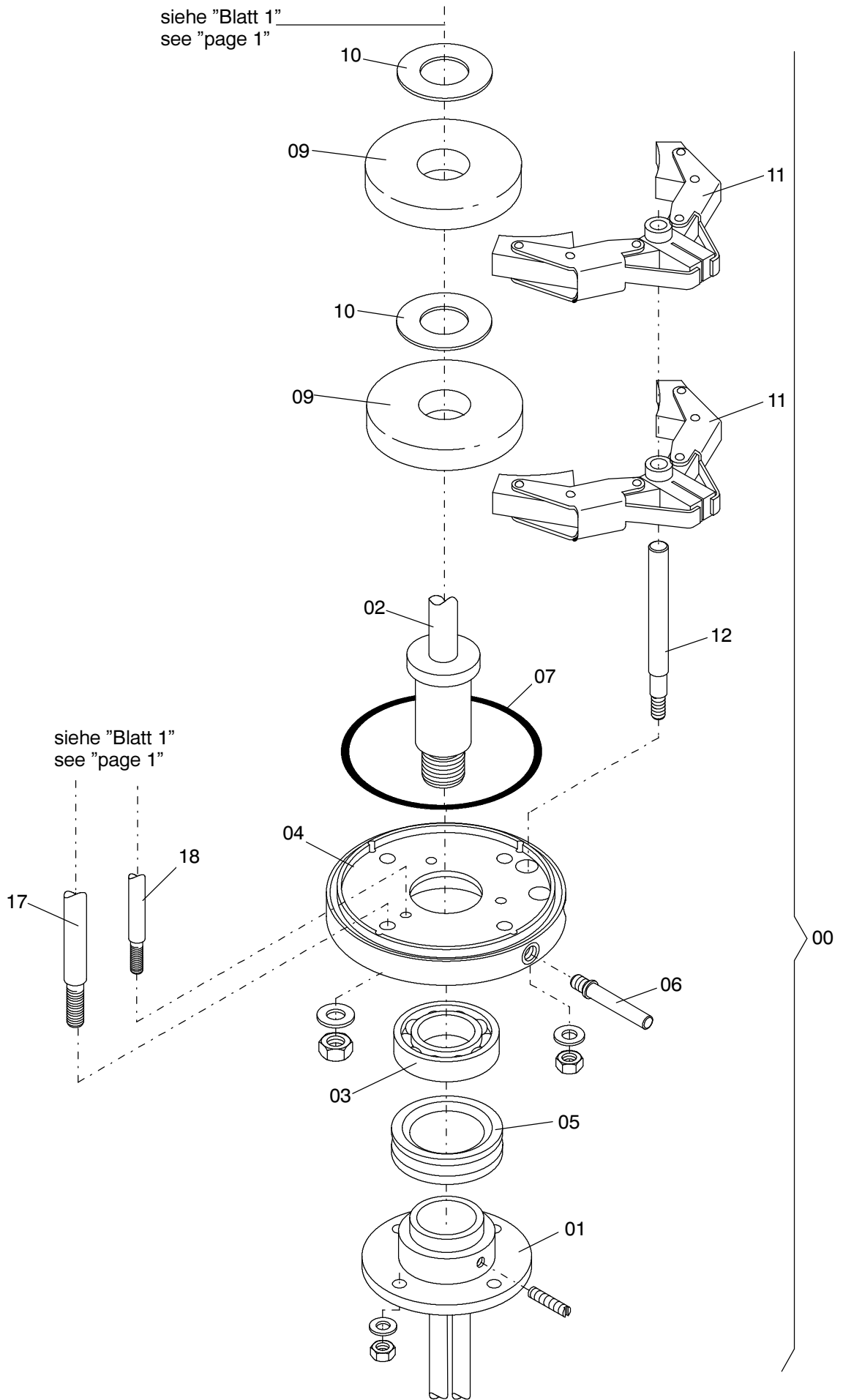

siehe "Blatt 1"
see "page 1"

90-2085

Seite/Page 2 / 4

Bild-Nr Fig Fig Fig Fig Bild nr	ET-Nr Part-No No. de Piece No. de Pieza No. del Pezzo Detalj nr	Stückzahl Qty Qte Ctd Qta Antal		Gegenstand Description Designation Descripcion Designazione Benaemning
00	621 132 40	1	Schleifringkörper, kpl.	Slip ring, assy.
00	551 341 40	1	Schleifringkörper, kpl.	Slip ring assy.
01	978 134 73	1	Flansch	Flange
02	978 135 73	1	Achse	Axle
03	368 169 99	1	Kugellager	Ball bearing
04	978 136 73	1	Grundplatte	Base plate
05	621 298 40	1	Dichtung	Seal
06	-	1	Mitnehmer	Cam
07	504 722 98	1	O-Ring	O-ring
08	978 137 73	1	Haube, kpl.	Hood assy.
09	978 138 73	2	Schleifring	Slip ring
10	978 139 73	3	Isolator	Insulator
11	978 140 73	2	Stromabnehmer	Collector
12	978 141 73	1	Bürstenbolzen	Brush pin
13	978 142 73	2	Schleifring	Slip ring
14	978 143 73	2	Isolerring	Insulation
15	978 144 73	1	Isolierdistanzstück	Insulation spacer
16	978 145 73	2	Stromabnehmer	Collector
17	978 146 73	2	Bürstenbolzen	Brush pin
18	-	1	Haltebolzen, kpl.	Pin assy.
01	604 913 40	1	Schleifringkörper, kpl.	Slip ring, assy.
02	979 207 73	1	Kugellager	Ball bearing
05	979 247 73	1	Deckel	Cover
06	979 208 73	1	O-Ring	O-Ring
09	979 210 73	1	Isolerring	Insulation
10	979 209 73	9	Schleifring	Slip ring
11	979 206 73	9	Stromabnehmer	Collector
16	979 214 73	1	Klemmbrett	Terminal board
18	300 981 73	1	Kabelverschraubung	Cable union
19	300 984 73	1	Kabelverschraubung	Cable union
25	979 211 73	1	Drehwinkelgeber	Angular indicator
30	979 216 73	2	Schalter	Switch
35	979 215 73	1	Kupplung	Coupling
36	*	1	Kabel 2,5m (4x10)	Cable
37	*	1	Kabel 2,5m (36x1)	Cable
38	*	1	Kabel 8,0m (4x10)	Cable
39	*	1	Kabel 8,0m (36x1)	Cable
40	571 119 40	1	Mitnehmer	Cam
			* Meterware, bei Bestellung Länge angeben	* Bulk ware, state length required
*	635 457 40	-	Kabel zu Bild-Nr. 36+38	Cable to fig-no: 36+38

**Schleifringkörper
Slip Ring**

90-2085

Seite/Page 3 / 4

Bild-Nr Fig Fig Fig Fig Bild nr	ET-Nr Part-No No. de Piece No. de Pieza No. del Pezzo Detalj nr	Stückzahl Qty Qte Ctd Qta Antal		Gegenstand Description Designation Descripcion Designazione Benaemning
*	654 200 40	-	Kabel zu Bild-Nr. 37+39	Cable to fig-no: 37+39
Schleifringkörper Slip Ring				<div style="border: 1px solid black; padding: 2px; display: inline-block;">90-2085</div> Seite/Page 4 / 4