

90-2094

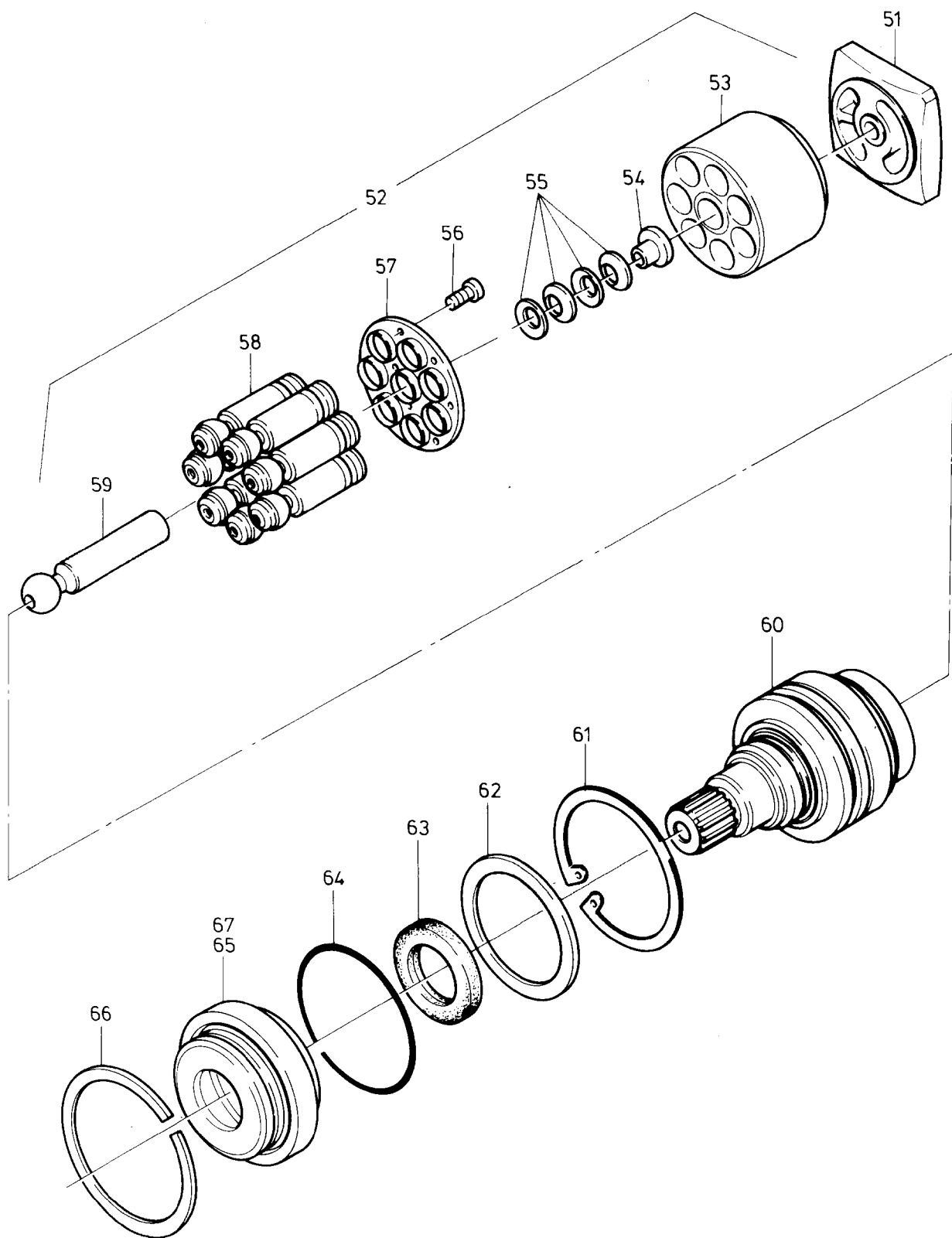

90-2094

Bild-Nr Fig Fig Fig Fig Bild nr	ET-Nr Part-No No. de Piece No. de Pieza No. del Pezzo Detailj nr	Stückzahl Qty Qte Ctd Qta Antal		Gegenstand Description Designation Description Designazione Benaemning
			Bild 1	Graphic 1
01	592 764 40		Hydr.-Motor, kpl.	Hydr.-motor assy.
02	-	1	Gehäuse	Housing
03	173 448 40	1	Verschlußschraube	Plug
04	762 797 73	1	Verstellung, kpl. Bild-Nr. 05-12,31-45	Adjustment assy. fig-nos: 05-12,31-45
05	762 775 73	1	Dichtung	Gasket
06	511 848 98	1	Gewindestift, 50 mm	Threaded pin
10	964 767	1	Mutter	Nut
11	344 888 99	2	Stift	Pin
12	762 798 73	1	Steuerteil, kpl. Bild-Nr. 13-30	Control part assy. fig-nos: 13-30
13	319 143 99	4	Schraube	Screw
14	762 777 73	1	Steuergehäuse	Control housing
15	964 663	2	Mutter	Nut
16	511 849 98	1	Gewindestift	Threaded pin
17	255 985 40	1	Verschlußschraube	Plug
18	964 770	4	Abreißstopfen	Breaking plug
20	762 778 73	1	O-Ring	O-ring
21	756 191 73	1	Gewindestift	Threaded pin
22	756 520 73	1	Steuerkolben	Piston valve
23	756 521 73	1	Steuerbuchse	Sleeve
24	342 616 99	1	Sicherungsring	Circlip
25	756 447 73	1	Feder	Spring
26	756 448 73	1	Federbolzen	Spring bolt
27	756 490 73	1	Einstellbuchse	Bush
28	762 799 73	1	Feder	Spring
29	762 800 73	1	Federteller	Spring plate
30	762 801 73	1	Feder	Spring
31	319 187 99	8	Schraube	Bolt
32	756 494 73	1	Abschlußplatte	Cover plate
33	762 781 73	3	O-Ring	O-ring
34	762 782 73	2	O-Ring	O-ring
35	756 452 73	2	Ventilführung	Valve guide
36	762 783 73	2	O-Ring	O-ring
37	756 453 73	2	Bolzen	Pin
38	756 454 73	2	Buchse	Bush
39	756 495 73	2	Stützring	Support ring
40	756 496 73	1	Variseal-Ring	Variseal-ring
41	756 497 73	1	Stellkolben	Piston
42	756 498 73	1	Stellzapfen	Regulation journal
43	505 935 98	1	Rechteckring	Quadring
Hydr.-Motor Hydr. Motor			90-2094 Seite/Page 3/4	

Bild-Nr Fig Fig Fig Fig Bild nr	ET-Nr Part-No No. de Piece No. de Pieza No. del Pezzo Detailj nr	Stückzahl Qty Qte Ctd Qta Antal		Gegenstand Description Designation Descripcion Designazione Benaemning
44	762 763 73	1	Gewindestift	Threaded pin
45	762 784 73	1	Deckel, kpl. Bild-Nr. 46-49	Cover assy. fig-nos: 46-49
46	319 157 99	4	Schraube	Bolt
47	756 499 73	1	Deckel	Cover
48	762 785 73	1	O-Ring	O-ring
49	255 679 40	1	Verschlußschraube	Plug
			Bild 2	Graphic 2
50	756 501 73	1	Triebwerk, kpl. Bild-Nr. 51,52,60-66	Transmission assy. fig-nos: 51,52,60-66
51	756 502 73	1	Steuerlinse	Control lens
52	756 200 73	1	Triebwerk, hydr. Teil, kpl. Bild-Nr. 53-59	Transmission, hydr. part assy. fig-nos: 53-59
53	757 441 73	1	Zylinder	Cylinder
54	756 205 73	1	Federteller	Spring plate
55	756 204 73	4	Tellerfeder	Cup spring
56	762 748 73	14	Schraube, brüniert	Screw, burnished
57	756 203 73	1	Rückzugplatte	Withdrawal plate
58	762 786 73	7	Kolben mit Kolbenringen	Piston with piston rings
59	756 202 73	1	Mittelzapfen	Trunnion
60	756 505 73	1	Triebwelle mit Lagersatz	Drive shaft with bearing set
61	342 684 99	1	Sicherungsring	Circlip
62	756 506 73	1	Stützscheibe	Supporting disk
63	762 769 73	1	Wellendichtring *	Shaft seal
64	762 787 73	1	O-Ring	O-ring
65	756 507 73	1	Verschlußring *	Cover
66	756 508 73	1	Sprengring	Snap ring
67	762 788 73	1	Verschlußring, kpl. mit Bild-Nr. 63	Cover assy. with fig-no: 63
-	762 395 73	-	Dichtsatz, kpl.	Seal kit assy.
-	973 125	-	Flüssigdichtung 50 ml zu Bild-Nr. 21,56	Fluid sealing to fig-nos: 21,56
-	989 946	-	Flüssigdichtung 50 ml (Rohrgewinde)	Fluid sealing (pipe thread)
			* Diese Teile können nur bei Werkstattreparatur verwendet werden	* No field repair item
Hydr.-Motor			90-2094	
Hydr. Motor			Seite/Page 4/4	