

Vierkreisschutzventil
4-Way Protection valve
 905-1700a 2/2

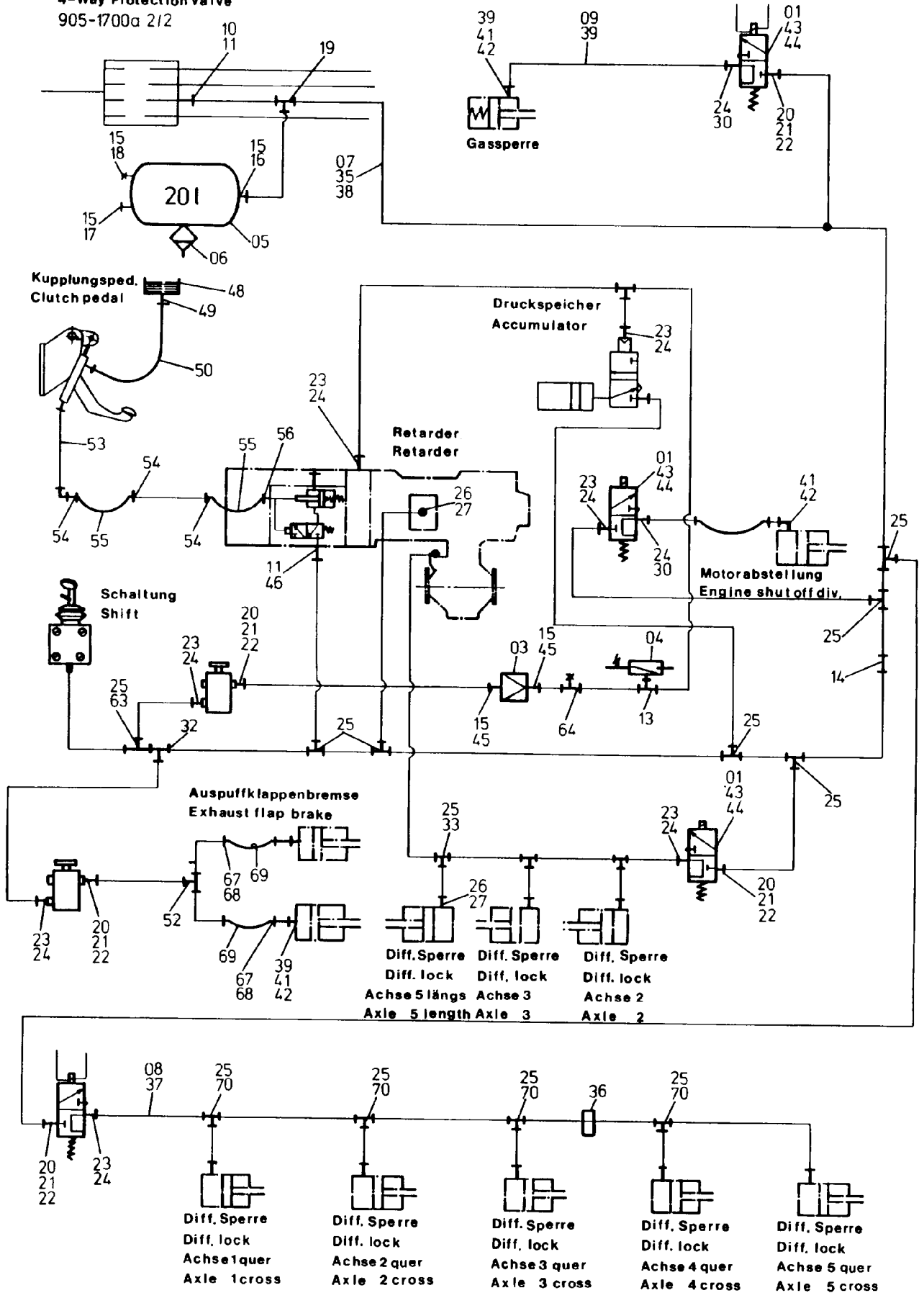

905-1700a1

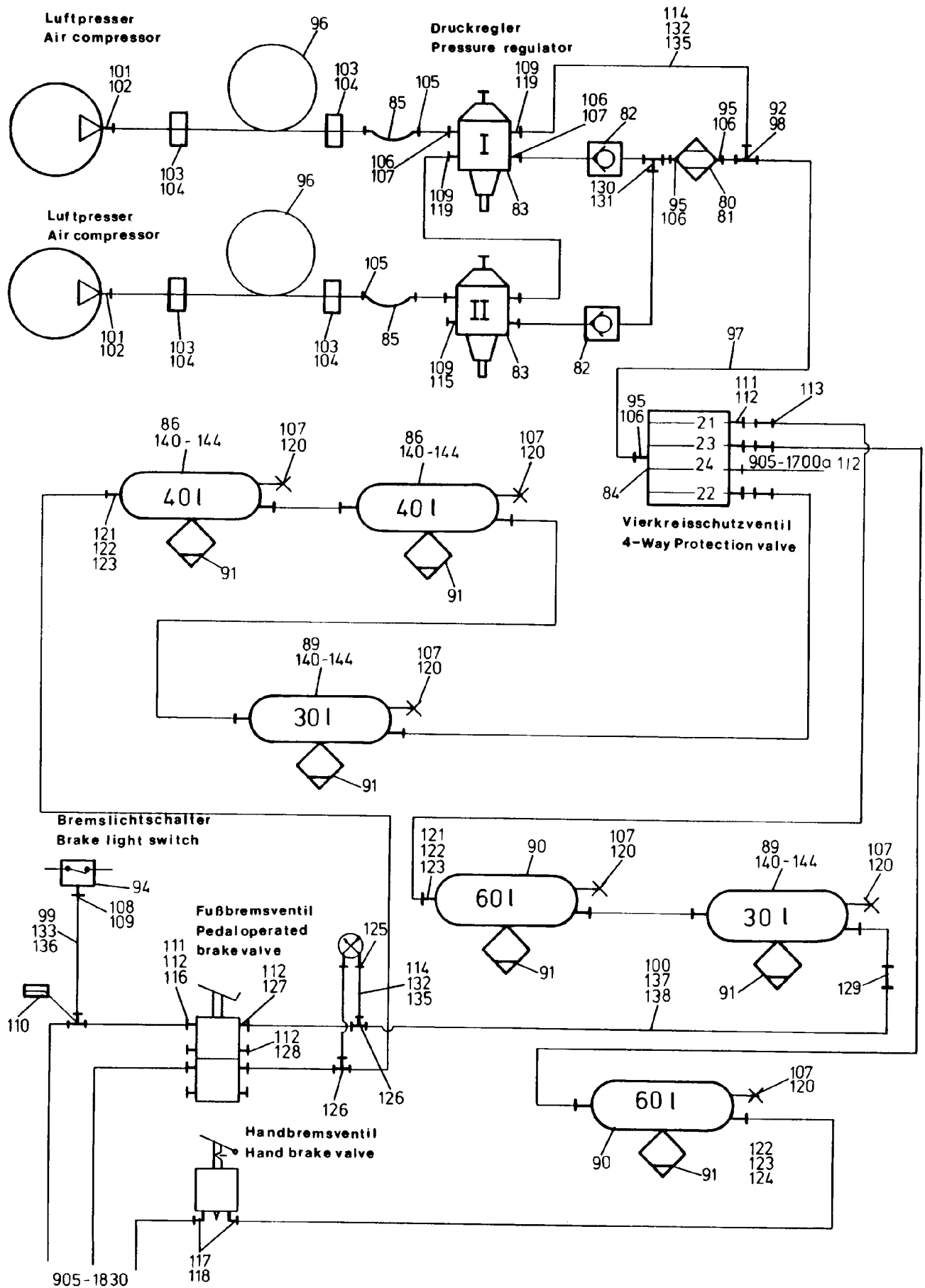

905-1700a1

Bild-Nr Fig Fig Fig Fig Bild nr	ET-Nr Part-No No. de Piece No. de Pieza No. del Pezzo Detalj nr	Stückzahl Qty Qte Ctd Qta Antal		Gegenstand Description Designation Descripcion Designazione Benaemning
			Bild 1	Graphic 1
01	207 323 40	4	Magnetventil	Solenoid valve
03	348 686 40	1	Druckbegrenzungsventil	Pressure relief valve
04	323 900 40	1	Druckschalter	Pressure switch
05	530 011 99	1	Luftbehälter 20 liter	Air tank
06	087 257 40	1	Entwässerungsventil	Drain valve
07	*	-	Tecalan-Rohr ø 15	Plastic pipe
08	*	-	Tecalan-Rohr ø 10	Plastic pipe
09	*	-	Tecalan-Rohr ø 6	Plastic pipe
10	192 182 40	1	Verschraubung	Union
11	192 183 40	2	Dichtring	Seal ring
13	180 265 40	1	Verschraubung	Union
14	372 400 99	1	Verschraubung	Union
15	192 181 40	4	Dichtring	Seal ring
16	372 377 99	1	Verschraubung	Union
17	207 362 40	1	Verschlussschraube	Plug
18	192 168 40	1	Prüfanschluß	Test point
19	372 614 99	1	Verschraubung	Union
20	208 931 40	5	Verschraubung	Union
21	192 203 40	5	Druckring	Thrust collar
22	192 204 40	5	O-Ring	O-ring
23	192 174 40	8	Verschraubung	Union
24	192 175 40	10	Dichtring	Seal ring
25	244 822 40	14	Verschraubung	Union
26	180 353 40	7	Verschraubung	Union
27	192 198 40	9	Dichtring	Seal ring
30	956 808 40	2	Verschraubung	Union
32	372 171 99	1	Verschraubung	Union
33	372 107 99	3	Verschraubung	Union
35	570 374 40	2	Rohrschelle	Pipe clamp
36	570 372 40	12	Rohrschelle	Clamp
37	007 577 98	65	Einsteckhülse (zu Bild-Nr. 08)	Plug-in sleeve (to fig-no: 08)
38	208 967 40	25	Einsteckhülse (zu Bild-Nr. 07)	Plug-in sleeve (to fig-no: 07)
39	007 575 98	10	Einsteckhülse (zu Bild-Nr. 09)	Plug-in sleeve (to fig-no: 09)
41	371 271 99	4	Überwurfmutter	Union nut
42	371 254 99	4	Schneidring	Olive
43	365 763 99	8	Schraube	Bolt
44	343 108 99	8	Federring	Lock washer
45	192 173 40	2	Verschraubung	Union
46	224 311 40	1	Verschraubung	Union

Bild-Nr Fig Fig Fig Fig Bild nr	ET-Nr Part-No No. de Piece No. de Pieza No. del Pezzo Detalj nr	Stückzahl Qty Qte Ctd Qta Antal		Gegenstand Description Designation Descripcion Designazione Benaemning
48	324 141 40	1	Ausgleichsbehälter	Expansion tank
49	502 848 98	1	Schelle	Clamp
50	*	-	Tecalanrohr ø 12	Plastic pipe
52	244 821 40	1	Verschraubung	Union
53	*	-	Rohr ø 8	Pipe
54	372 399 99	3	Verschraubung	Union
55	234 678 40	2	Schlauch NW 6	Hose
56	372 433 99	1	Verschraubung	Union
63	372 891 99	1	Verschraubung	Union
64	415 541 40	1	Prüfanschluß	Test point
67	224 199 40	6	Schlauchstutzen	Hose connection
68	207 489 40	6	Schlauchklemme	Hose clamp
69	192 189 40	3	Schlauch 600 lg.	Hose
70	371 952 99	4	Verschraubung	Union
			Bild 2	Graphic 2
80	270 990 40	1	Lufttrockner	Air dryer
81	432 184 40	1	Anschlußkabel	Connecting cable
82	502 836 98	2	Rückschlagventil	Non-return valve
83	432 185 40	1	Druckregler	Pressure regulator
84	192 152 40	1	Vierkreis-Schutzventil	4 Circuit protection valve
85	192 147 40	1	Schlauch	Hose
86	530 013 99	2	Luftbehälter 40 Ltr.	Air tank
89	530 012 99	2	Luftbehälter 30 Ltr.	Air tank
90	416 571 40	2	Luftbehälter 60 Ltr.	Air tank
91	087 257 40	6	Entwässerungsventil	Drain valve
92	372 896 99	1	Verschraubung	Union
94	224 189 40	1	Bremslichtschalter	Brake light switch
95	634 298 40	3	Stutzen	Socket
96	*	-	Rohr ø 18	Pipe
97	*	-	Rohr ø 22	Pipe
98	373 759 99	1	Verschraubung	Union
99	*	-	Tecalanrohr ø 10	Plastic pipe
100	*	-	Tecalanrohr ø 15	Plastic pipe
101	551 531 40	2	Stutzen	Socket
102	551 404 40	4	Stutzen	Socket
103	003 288 98	6	Schelle	Clamp
104	243 643 40	6	Halter	Retainer
105	511 169 98	4	Stutzen	Socket
106	576 442 40	7	Stutzen	Socket
107	192 181 40	40	Dichtring	Seal ring
108	192 174 40	1	Verschraubung	Union

Bild-Nr Fig Fig Fig Fig Bild nr	ET-Nr Part-No No. de Piece No. de Pieza No. del Pezzo Detalj nr	Stückzahl Qty Qte Ctd Qta Antal		Gegenstand Description Designation Descripcion Designazione Benaemning
109	192 175 40	4	Dichtring	Seal ring
110	509 590 98	1	Stutzen	Socket
111	244 819 40	6	Verschraubung	Union
112	192 183 40	30	Dichtring	Seal ring
113	510 222 98	8	Stutzen	Socket
114	*	-	Tecalanrohr ø 6	Plastic pipe
115	313 181 99	1	Verschlussschraube	Plug
116	551 444 40	9	Verschraubung	Union
117	551 617 40	2	Verschraubung	Union
118	192 198 40	2	Dichtring	Seal ring
119	956 808 40	3	Verschraubung	Union
120	192 168 40	6	Prüfanschluß	Test point
121	192 191 40	12	Verschraubung	Union
122	192 201 40	12	Druckring	Thrust collar
123	192 202 40	10	O-Ring	O-ring
124	244 823 40	3	Verschraubung	Union
125	372 169 99	2	Verschraubung	Union
126	244 824 40	2	Verschraubung	Union
127	192 182 40	2	Verschraubung	Union
128	313 194 99	4	Verschlussschraube	Plug
129	509 811 98	8	Stutzen	Socket
130	372 910 99	2	Verschraubung	Union
131	509 461 98	1	Stutzen	Socket
132	171 288 40	6	Klemmring	Clamping ring
133	159 966 40	60	Klemmring	Clamping ring
135	007 575 98	4	Einsteckhülse	Plug-in sleeve
136	007 577 98	60	Einsteckhülse	Plug-in sleeve
137	208 967 40	90	Einsteckhülse	Plug-in sleeve
138	180 054 40	50	Klemmring	Clamping ring
140	270 997 40	4	Spannschelle	Clamp clip
141	346 527 40	4	Spannschelle	Clamp clip
142	269 251 40	6	Spannschelle	Clamp clip
143	307 576 99	28	Schraube	Bolt
144	334 690 99	28	Mutter	Nut
-	007 164 98	8	Schelle für Schutzschlauch	Clamp for protection hose
-	270 992 40	9	Geräuschkämpfer	Noise absorber
-	*	-	Vacu-Flex-Schlauch	Hose
-	*	-	Schutzschlauch	Protection hose
-	*	-	Scheuerschutzwendel	Protective coil
			* Meterware, bei Bestellung Länge angeben	* Bulk ware, state length required
*	211 303 99	-	Tecalanrohr ø 15	Plastic pipe

Bild-Nr Fig Fig Fig Fig Bild nr	ET-Nr Part-No No. de Piece No. de Pieza No. del Pezzo Detalj nr	Stückzahl Qty Qte Ctd Qta Antal		Gegenstand Description Designation Descripcion Designazione Benaemning
*	501 019 98	-	Tecalanrohr ø 10	Plastic pipe
*	211 240 99	-	Tecalanrohr ø 6	Plastic pipe
*	211 302 99	-	Tecalanrohr ø 12	Plastic pipe
*	215 805 99	-	Rohr ø 8	Pipe
*	215 812 99	-	Rohr ø 18	Pipe
*	215 495 99	-	Rohr ø 22	Pipe
*	502 335 98	-	Tecalanrohr ø 6	Plastic pipe
*	160 389 40	-	Vacu-Flex-Schlauch NW 35	Hose
*	270 252 40	-	Schutzschlauch PG 48	Protection hose
*	180 101 40	-	Scheuerschutzwendel	Protective coil