

905-2115b

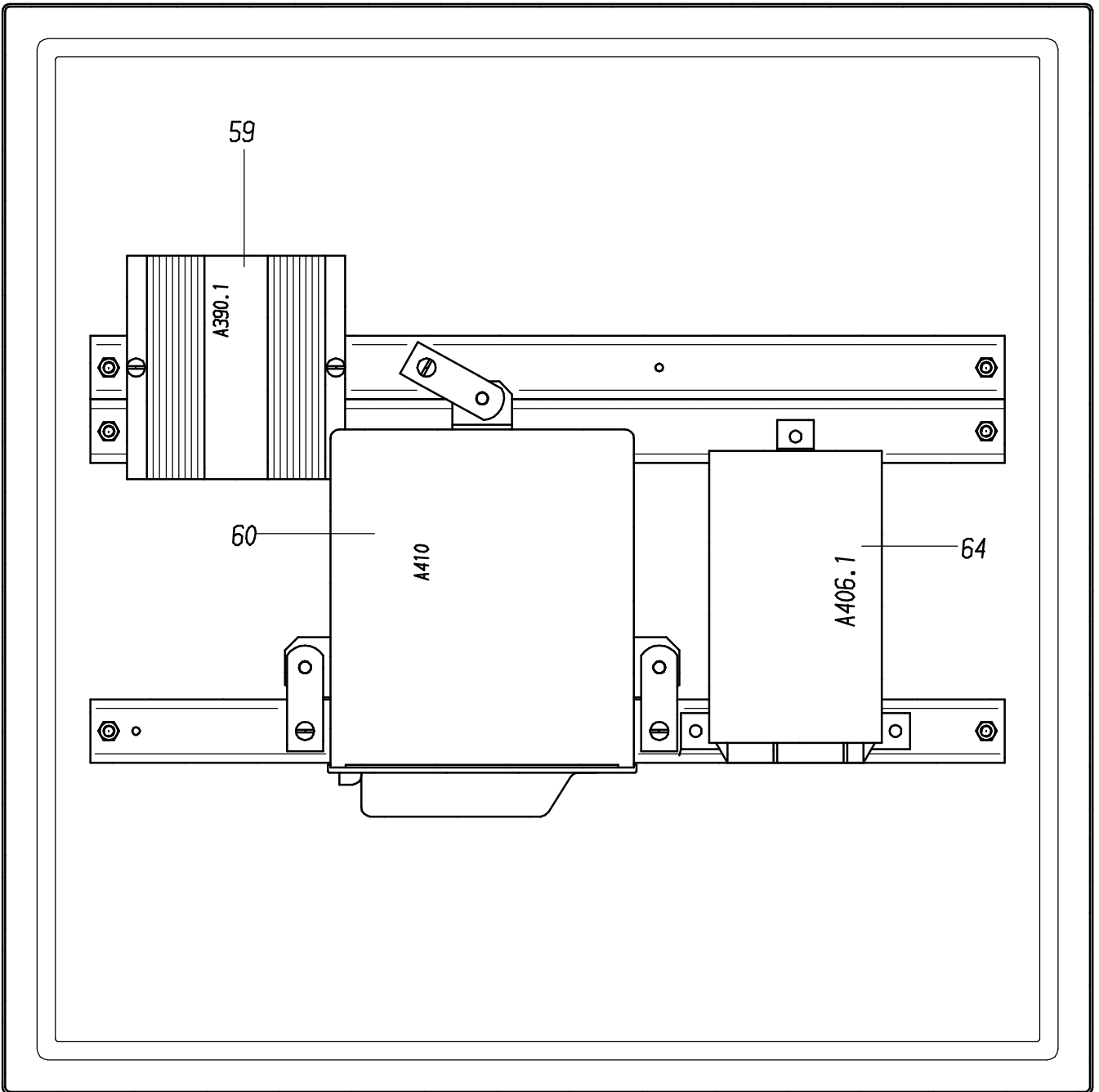

Bild-Nr Fig Fig Fig Fig Bild nr	ET-Nr Part-No No. de Piece No. de Pieza No. del Pezzo Detalj nr	Stückzahl Qty Qte Ctd Qta Antal		Gegenstand Description Designation Descripcion Designazione Benaemning
01	875 071 40	1	Hauptschaltkasten X300	Main switch cabinet
02	270 285 40	1	Schaltschrank	Switch cabinet
11	358 293 40	1	Leistungsrelais	Relay
12	256 878 40	1	Leistungsschaltrelais	Feeder relay
13	461 251 40	1	Impulsgeber	Sender
14	226 447 40	1	Warnlichtgeber	Hazard transmitter
19	979 986 73	1	Flamm-Glüh-Anlage	Flame glow equipment
25	551 005 40	13	Relaiskoppler	Coupling relais
26	180 221 40	15	Schaltrelais	Switching relay
27	324 068 40	8	Tragsockel	Supporting trestle
28	346 528 40	2	Relaisbaustein	Relay modul
29	346 529 40	4	Industrierelais	Relay assy.
30	635 575 40	4	Haltebügel	Retainer
31	621 952 40	2	Diodenmodul	Diode assy.
37	356 274 40	3	Reihen клемme	Series terminal
39	356 272 40	1	Abschlußplatte	Cover plate
40	634 144 40	34	Sicherungsklemme	Fuse clamp
41	509 418 98	11	Flachsicherung 5A	Fuse
42	509 416 98	15	Flachsicherung 7,5 A	Fuse
43	509 417 98	26	Flachsicherung 10 A	Fuse
44	509 419 98	4	Flachsicherung 15 A	Fuse
45	511 270 98	2	Flachsicherungseinsatz 20 A	Fuse insert
46	509 420 98	2	Flachsicherung	Fuse
53	634 693 40	8	Trennscheibe	Spacer
54	634 686 40	4	Brücke 10 pol	Bridge
56	592 603 40	1	Querverbinder	Cross connection
57	551 696 40	22	Querverbinder	Cross connection
58	057 278 40	1	Steckdose	Plug
59	551 334 40	1	Spannungswandler	Voltage converter
60		1	Getriebeelektronik	Gearbox elec.
61	356 265 40	2	Endklammer	Clamp
64		1	Getriebeelektronik	Gearbox elec.
95	296 357 40	2	Diode	Diode

Hauptschaltkasten X300
Main Switch Cabinet X300

905-2115b

Seite/Page 3 / 3