

906-3650c1

Seite/Page 1 / 3

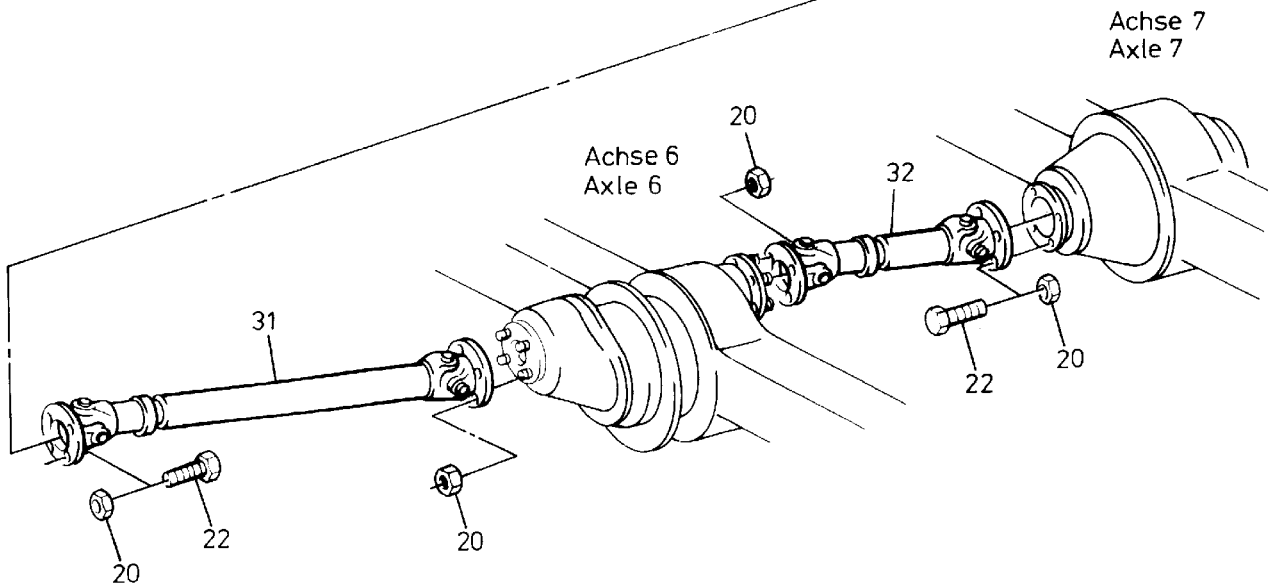
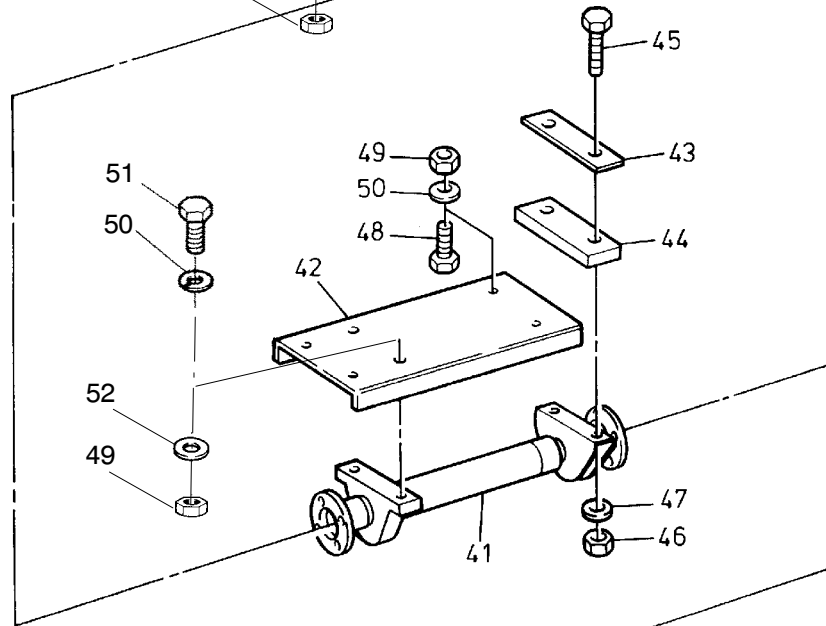
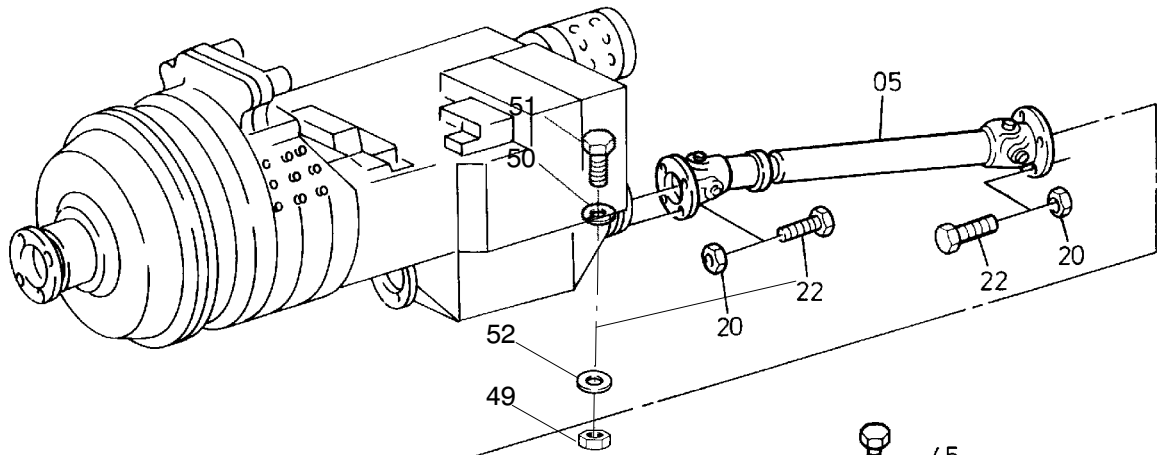

906-3650c1

Seite/Page 2 / 3

Bild-Nr Fig Fig Fig Fig Bild nr	ET-Nr Part-No No. de Piece No. de Pieza No. del Pezzo Detalj nr	Stückzahl Qty Qte Ctd Qta Antal		Gegenstand Description Designation Descripcion Designazione Benaemning
01	645 189 40	1	Gelenkzwischenwelle	Joint shaft
02	632 979 40	1	Gelenkwelle	Joint shaft
03	888 275 40	1	Gelenkwelle	Joint shaft
04	526 327 40	1	Gelenkwelle	Joint shaft
05	526 321 40	1	Gelenkwelle	Joint shaft
05	552 642 40	1	Gelenkwelle-Japanausführung	Joint shaft Japan-Design
13	308 681 99	2	Skt.-Schraube	Bolt
14	316 212 99	2	Scheibe	Disc
15	501 162 98	8	Skt.-Mutter	Nut
16	506 202 98	4	Skt.-Schraube	Bolt
17	307 579	4	Skt.-Schraube	Bolt
20	502 686 98	44	Skt.-Mutter	Nut
22	501 162 98	24	Skt.-Schraube	Bolt
			Nur bei nicht angetriebener Achse 7:	Applies to non drive axle No. 7
31	526 323 40	1	Gelenkwelle (14x6)	Joint shaft
			Nur bei angetriebener Achse 7:	Applies to drive axle No. 7
31	526 326 40	1	Gelenkwelle (14x8)	Joint shaft
-	780 628 73	1	Doppelschmiernippel	Double-Greasesnipple
32	526 322 40		Gelenkwelle (14x8)	Joint shaft
			Nur bei Ausführung ohne Wirbelstrombremse	Only for version "without vortex brake"
41	553 761 40	1	Gelenkzwischenwelle	Joint shaft
42	526 655 40	1	Lagerkonsole	Console
43	526 634 40	1	Verstärkungsblech	Gusset
44	526 635 40	1	Verstärkungsblech	Gusset
45	500 195 98	2	Skt.-Schraube	Bolt
46	334 694 99	2	Skt.-Mutter	Nut
47	120 739 12	2	Scheibe	Disc
48	307 615 99	4	Skt.-Schraube	Bolt
49	507 750 98	6	Skt.-Mutter	Nut
50	316 212 99	10	Scheibe	Disc
51	510 035 98	2	Skt.-Schraube	Bolt
52	120 737 12	2	Scheibe	Disc
			Hinweis: Ausführung mit Wirbelstrombremse siehe EL-Blatt 906-3658,etc.	Note: for version with vortex brake see page 906-3658,etc.

**Gelenkwelleneinbau
Joint Shaft Mounting**

906-3650c1

Seite/Page 3 / 3