

907-1812a

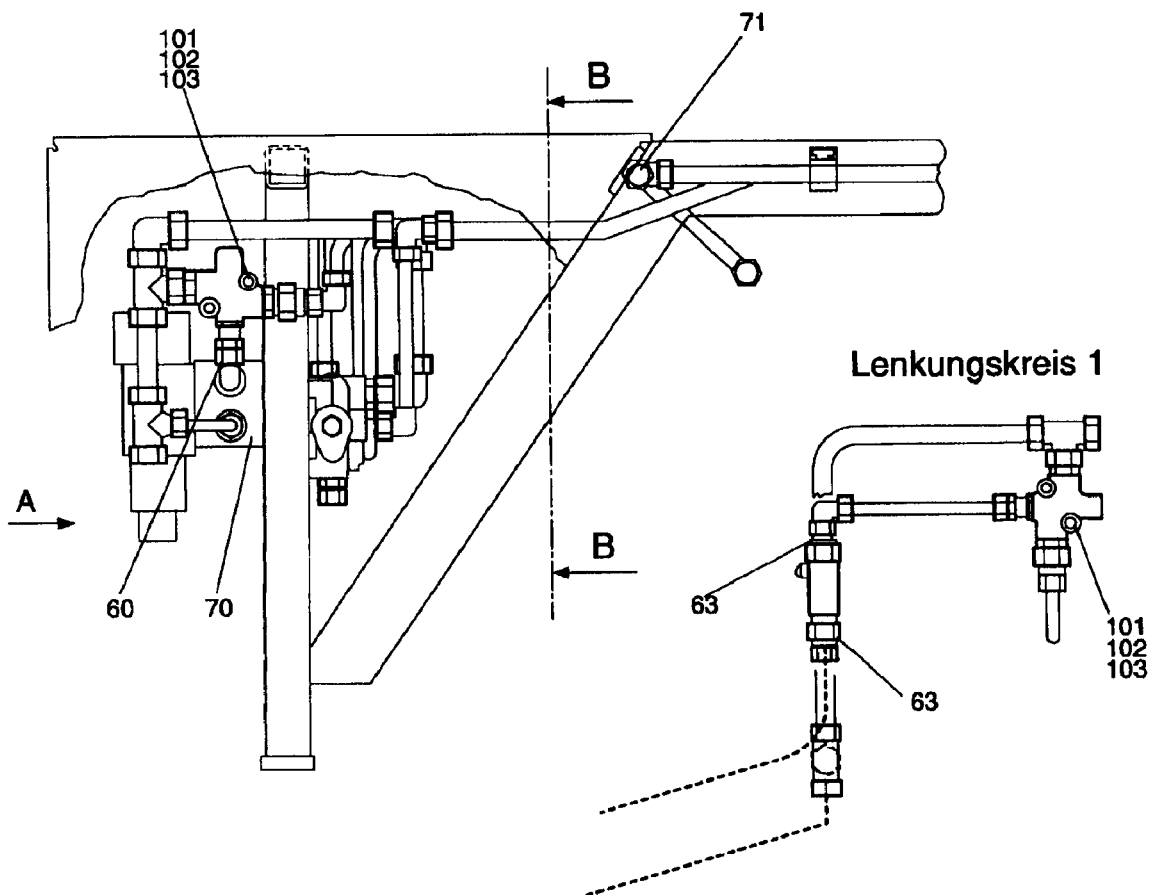
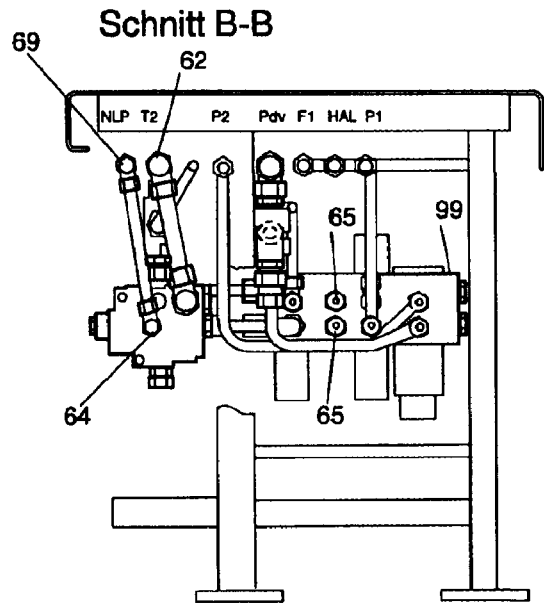
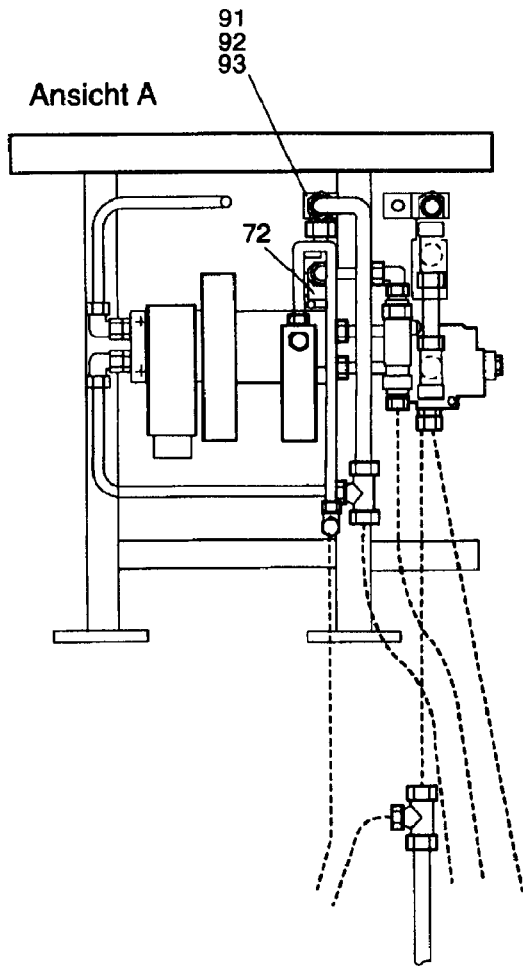

907-1812a

Bild-Nr Fig Fig Fig Fig Bild nr	ET-Nr Part-No No. de Piece No. de Pieza No. del Pezzo Detalj nr	Stückzahl Qty Qte Ctd Qta Antal		Gegenstand Description Designation Descripción Designazione Benaemning
01	-	1	Halbblock Hydrolenkung siehe EL-Blatt 90-2998	Semi-integral power steering gear, see page 90-2998
02	551 531 40	6	Stutzen	Socket
03	551 483 40	5	Stutzen	Socket
04	551 301 40	2	Stutzen	Socket
05	551 480 40	2	Stutzen	Socket
06	604 411 40	2	Stutzen	Socket
11	-	1	Steuerblock Lenkung I s. EL-Blatt 90-2895	Control block steering I see page 90-2895
12	551 452 40	10	Stutzen	Socket
14	509 804 98	4	Schraube	Screw
15	509 861 98	4	Mutter	Nut
16	551 481 40	1	Stutzen	Socket
21	510 179 98	8	Klemmhälftenpaar	Pair of half clamps
22	509 778 98	16	Schraube	Screw
23	504 030 98	16	Mutter	Nut
24	509 878 98	16	Scheibe	Washer
31	592 505 40	2	Schlauch NW 12x830	Hose
32	592 504 40	2	Schlauch NW 12x730	Hose
33	592 518 40	4	Schlauch NW 12x3200	Hose
34	592 549 40	1	Schlauch NW 12x525	Hose
34	547 911 40	1	Schlauch NW 12x700 ab Bau Nr. 71 019	Hose from s/no. 71 019 up
36	592 514 40	1	Schlauch NW 12x1880	Hose
41	551 940 40	2	Stromregelventil	Flow control valve
42	-	1	Durchflußanzeiger siehe EL-Blatt 90-0338, etc.	Flow indicator see page 90-0338, etc.
44	-	1	Ventilblock siehe EL-Blatt 90-1037	Valve block see page 90-1037
45	551 452 40	11	Verschraubung	Union
46	551 301 40	7	Verschraubung	Union
47	551 481 40	2	Verschraubung	Union
48	576 391 40	2	Verschraubung	Union
49	551 531 40	5	Verschraubung	Union
50	551 480 40	2	Verschraubung	Union
51	551 441 40	2	Verschraubung	Union
52	551 389 40	5	Verschraubung	Union
53	509 811 98	12	Verschraubung	Union
54	510 201 98	2	Verschraubung	Union
55	509 547 98	1	Verschraubung	Union
56	551 478 40	1	Verschraubung	Union

**Lenkungshydraulik
Steering Hydraulics**

907-1812a

Seite/Page 3 / 5

Bild-Nr Fig Fig Fig Fig Bild nr	ET-Nr Part-No No. de Piece No. de Pieza No. del Pezzo Detalj nr	Stückzahl Qty Qte Ctd Qta Antal		Gegenstand Description Designation Descripción Designazione Benaeming
57	576 412 40	4	Verschraubung	Union
60	551 279 40	2	Verschraubung	Union
61	509 426 98	2	Verschraubung	Union
62	509 461 98	1	Verschraubung	Union
63	551 483 40	4	Verschraubung	Union
64	551 451 40	2	Verschraubung	Union
65	510 200 98	2	Verschlußschraube	Plug
69	509 545 98	10	Verschraubung	Union
70	-	1	siehe EL-Blatt "Steuerblock Lenkung II"	see page "Control block steering II"
71	510 391 98	1	Verschraubung	Union
72	153 646 40	4	Kupplung	Coupling
90	510 179 98	6	Klemmhälftenpaar	Pair of half clamps
91	510 176 98	23	Klemmhälftenpaar	Pair of half clamps
92	510 177 98	8	Klemmhälftenpaar	Pair of half clamps
93	510 390 98	3	Klemmhälftenpaar	Pair of half clamps
95	509 778 98	72	Schraube	Screw
96	510 080 98	4	Schraube	Screw
97	504 030 98	76	Mutter	Nut
98	509 878 98	76	Scheibe	Washer
99	509 787 98	4	Schraube	Screw
100	509 796 98	2	Schraube	Bolt
101	509 798 98	4	Schraube	Bolt
102	509 863 98	6	Mutter	Nut
103	510 314 98	6	Scheibe	Washer
116	592 509 40	1	Schlauch NW 12x1290	Hose
117	592 508 40	1	Schlauch NW 12x1225	Hose
118	592 557 40	1	Schlauch NW 20x630	Hose
119	592 559 40	1	Schlauch NW 20x1215	Hose
123	551 853 40	2	Schlauch NW 12x1080	Hose
125	551 533 40	6	Verschraubung	Union
			* Meterware, bei Bestellung Länge angeben	* Bulk ware, state length required
*	215 811 99	-	Rohr ø 15	Pipe
-	509 809 98	nB	Überwurfmutter ø 15	Union nut
-	371 242 99	nB	Schneidring ø 15	Olive
*	214 774 99	-	Rohr ø 16	Pipe
-	510 008 98	nB	Überwurfmutter ø 16	Union nut
-	371 231 99	nB	Schneidring ø 16	Olive
*	215 812 99	-	Rohr ø 18	Pipe
*	215 495 99	-	Rohr ø 22	Pipe

Bild-Nr Fig Fig Fig Fig Bild nr	ET-Nr Part-No No. de Piece No. de Pieza No. del Pezzo Detalj nr	Stückzahl Qty Qte Ctd Qta Antal		Gegenstand Description Designation Descripcion Designazione Benaemning
-	510 017 98	nB	Überwurfmutter ø 22	Union nut
-	371 244 99	nB	Schneidring ø 22	Olive
126	576 024 40	2	Schlauch NW 11x650	Hose
127	576 025 40	2	Schlauch NW 11x700	Hose
128	576 024 40	2	Schlauch NW 11x760	Hose
129	576 026 40	2	Schlauch NW 11x760	Hose
130	546 454 40	2	Schlauch NW11x1400	Hose
131	592 200 40	8	Prüfanschluß	Test point
132	224 301 40	8	O-Ring	O-ring
133	224 299 40	8	Druckregler	Pressure regulator
134	509 890 98	8	Mutter	Nut
135	592 201 40	8	Stutzen	Socket
136	604 677 40	2	Lenkzylinder	Steering cylinder
137	450 620 40	4	Kugelgelenktopf	Knuckle
138	551 533 40	8	Stutzen	Socket
139	551 958 40	6	Stutzen	Socket
140	551 380 40	2	Stutzen	Socket