

**908-1230**

Seite/Page 1 / 4

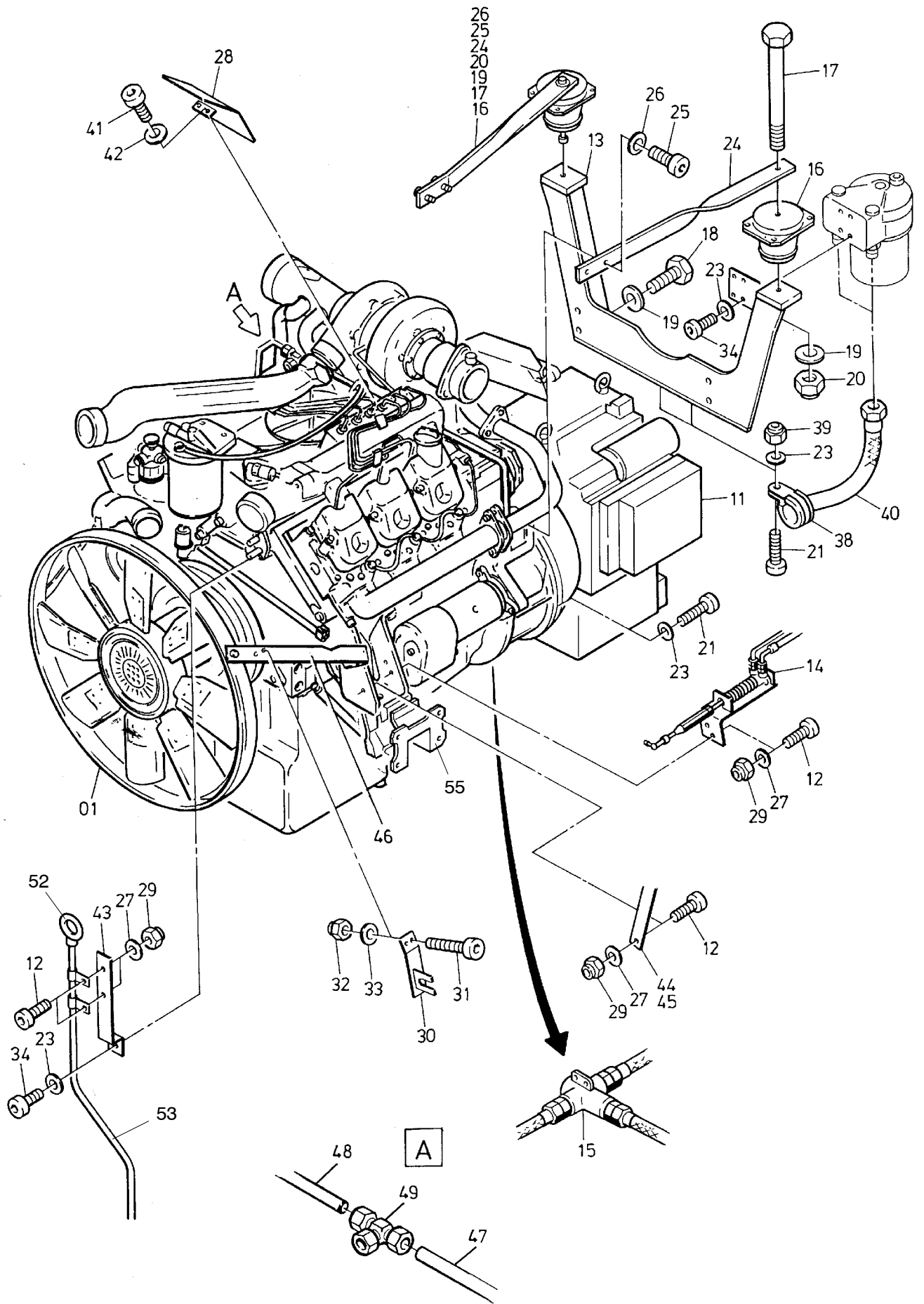

**908-1230**

Seite/Page 2 / 4

Bild-Nr Fig Fig Fig Fig Bild nr	ET-Nr Part-No No. de Piece No. de Pieza No. del Pezzo Detalj nr	Stückzahl Qty Qte Ctd Qta Antal		Gegenstand Description Designation Descripcion Designazione Benaemning
01	515 442 40	1	Dieselmotor	Diesel engine
-	979 431 73	1	Einspritzpumpe mit Regler	Injection pump with governor
02	348 966 40	2	Thermostat	Thermostat
03	412 124 12	1	Temperaturgeber	Temperature transmitter
04	760 387 00	1	1 Ltr. Filtereinsatz - Kraftstoff oder	Element - fuel or
-	760 590 00	2	0,5 Ltr. Filtereinsatz - Kraftstoff	Element - fuel
05	760 424 00	1	Filtereinsatz - Öl	Element - oil
06	760 884 73	1	Anlasser	Starter
-	778 422 73	1	Magnetschalter	Solenoid
07	761 924 73	6	Ventildeckeldichtung	Gasket, valve cover
08	394 904 40	1	Lichtmaschine	Generator
-	778 419 73	1	Reglerschalter	Regulator switch
09	430 546 73	1	Keilriemensatz	V-belt set
10	973 927 73	1	Öldruckgeber, M14x1,5	Oil pressure gauge
10	263 311 40	1	Öldruckgeber, M18x1,5	Oil pressure gauge
11	515 655 40	1	Getriebe kpl. Getriebeteile, s. EL-Blatt 90-1062 - 90-1079	Gearbox assy. Gearbox parts, see page 90-1062 - 90-1079
-	473 596 12	1	Dichtsatz, kpl	Seal kit
12	509 788 98	3	Schraube	Screw
13	542 088 40	1	Rahmen	Frame
14	-	1	Drehzahlverstellung s. EL-Blatt 908-1235	Speed control cable see page 908-1235
15	-	1	Ölthermostat s. EL-Blatt 908-1240	Oil thermostat see page 908-1240
16	551 076 40	2	Megi-Puffer	Silent bloc
17	509 824 98	2	Schraube	Bolt
18	509 847 98	4	Schraube	Bolt
19	510 496 98	8	Scheibe	Washer
20	509 908 98	2	Mutter	Nut
21	509 795 98	14	Schraube	Bolt
22	509 796 98	2	Schraube	Bolt
23	510 314 98	25	Scheibe	Washer
24	542 094 40	2	Halter	Retainer
25	509 814 98	4	Schraube	Bolt
26	510 495 98	4	Scheibe	Washer
27	510 321 98	6	Scheibe	Washer
28	542 330 40	1	Abdeckung	Cover
29	509 870 98	3	Mutter	Nut
30	542 211 40	1	Halter	Retainer

**Anbauteile Motor und Getriebe  
Mounting Parts Engine and Gearbox**

**908-1230**

Seite/Page 3 / 4

Bild-Nr Fig Fig Fig Fig Bild nr	ET-Nr Part-No No. de Piece No. de Pieza No. del Pezzo Detalj nr	Stückzahl Qty Qte Ctd Qta Antal		Gegenstand Description Designation Descripcion Designazione Benaemning
31	509 777 98	2	Schraube	Screw
32	509 869 98	2	Mutter	Nut
33	340 506 99	2	Scheibe	Washer
34	509 793 98	5	Schraube	Bolt
35	542 217 40	1	Halter	Retainer
36	542 218 40	1	Klemmnippel	Nipple
37	509 882 98	1	Splint	Cotter pin
38	007 625 98	2	Schelle	Clamp
39	509 876 98	2	Mutter	Nut
40	592 243 40	2	Schlauchleitung NW 25x1600	Hose assy.
41	510 351 98	1	Schraube	Bolt
42	510 494 98	2	Scheibe	Washer
43	543 262 40	1	Halter	Retainer
44	542 332 40	1	Halter	Retainer
45	529 086 40	1	Initiator	Initiator
46	543 735 40	1	Halter	Retainer
47	546 040 40	1	Konstantdrosselrohr rechts	Constant thottle pipe, r.h.
48	546 041 40	1	Konstantdrosselrohr links	Constant thottle pipe, l.h.
49	509 501 98	1	Stutzen	Socket
50	432 327 40	2	Schraubstutzen	Socket
51	339 932 99	2	Dichtring	Seal ring
-	621 198 40	1	Ölablaßschraube mit Dichtring	Oil drain plug with seal ring
52	430 565 73	1	Peilstab	Dipstick
53	430 566 73	1	Führungsrohr	Guide tube
55	410 634 12	2	Motorlagerung	Engine suspension
56	407 311 12	1	Gehäusekopf	Case head
57	760 654 00	1	Gehäuse	Housing
61	411 902 12	1	Deckel	Cover
63	760 407 00	1	Gehäuse	Housing