

908-1280-1

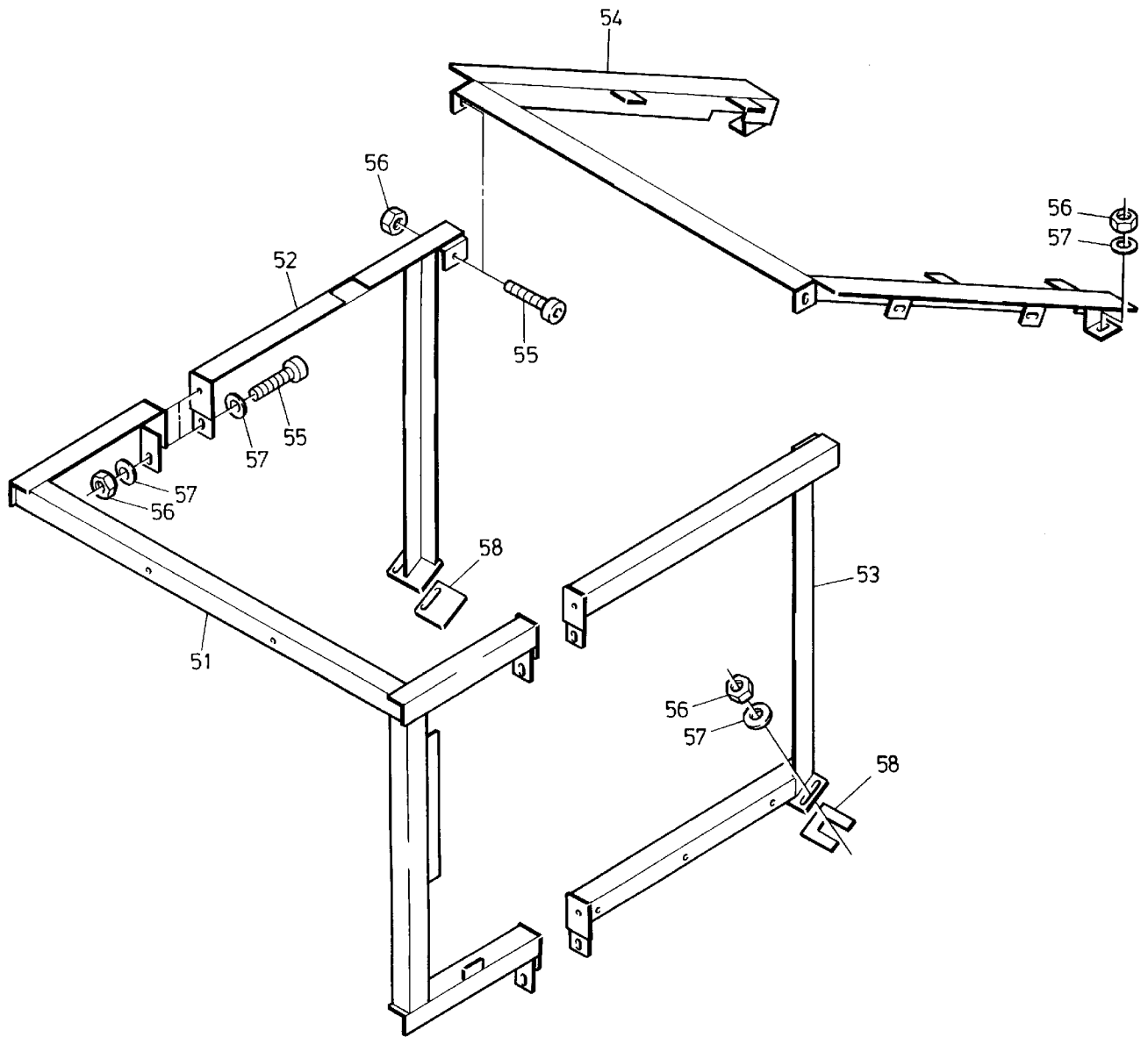

908-1280-1

Bild-Nr Fig Fig Fig Fig Bild nr	ET-Nr Part-No No. de Piece No. de Pieza No. del Pezzo Detailj nr	Stückzahl Qty Qte Ctd Qta Antal		Gegegenstand Description Designation Description Designazione Benaemning
			Bild 1	Graphic 1
01	394 636 40	15	Riegelverschluß	Locking bar
02	542 583 40	1	Motorhaube	Hood
03	542 582 40	1	Motorhaube	Hood
04	542 581 40	1	Motorhaube	Hood
05	542 406 40	1	Motorhaube	Hood
07	542 404 40	1	Motorhaube	Hood
10	542 401 40	1	Motorhaube	Hood
11	542 586 40	1	Motorhaube	Hood
12	544 792 40	1	Motorhaube	Hood
13	509 789 98	10	Schraube	Screw
14	509 862 98	7	Mutter	Nut
15	510 321 98	6	Scheibe	Washer
16	509 769 98	6	Federring	Lock washer
20	*	1	Anschlagprofil 895mm	Profile
22	551 397 40	4	Klammer	Clamp
23	551 398 40	4	Schraube	Screw
26	*	-	Köderprofil	Profile joint
32	509 775 98	2	Schraube	Screw
33	509 860 98	2	Mutter	Nut
34	340 461 99	2	Scheibe	Washer
-	544 799 40	1	Deckel Filterverkleidung	Cover
-	544 798 40	1	Luftfilterverkleidung	Covering
-	544 744 40	2	Distanzblech	Distance sheet
			Bild 2	Graphic 2
51	544 797 40	1	Rahmen	Frame
52	542 413 40	1	Rahmen	Frame
53	542 410 40	1	Rahmen	Frame
54	542 245 40	1	Rahmen	Frame
55	509 789 98	8	Schraube	Screw
56	509 870 98	8	Mutter	Nut
57	510 321 98	10	Scheibe	Washer
58	542 587 40	6	Ausgleichsscheibe	Shim
-	542 593 40	1	Kühlervverkleidung	Covering
-	509 914 98	4	Schraube	Bolt
-	509 860 98	4	Mutter	Nut
-	340 461 99	4	Scheibe	Washer
			* Meterware, bei Bestellung Länge angeben	* Bulk ware, state length required
*	551 394 40	-	Köderprofil	Profile joint
*	551 393 40	-	Anschlagprofil	Profile
Verkleidung - Motor Covering - Engine				908-1280-1 Seite/Page 3/3