

908-1280a

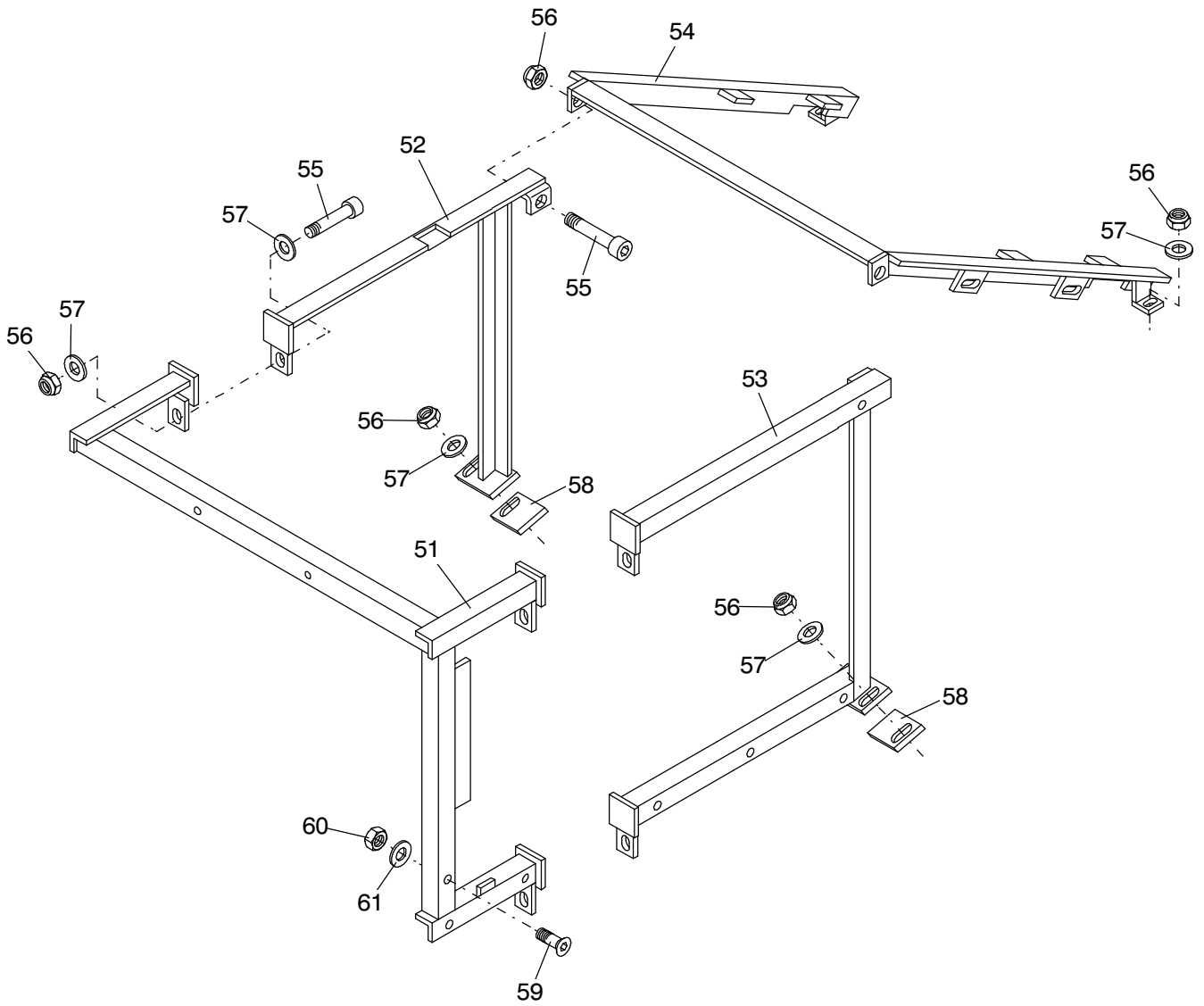

908-1280a

Seite/Page 2 / 4

Bild-Nr Fig Fig Fig Fig Bild nr	ET-Nr Part-No No. de Piece No. de Pieza No. del Pezzo Detalj nr	Stückzahl Qty Qte Ctd Qta Antal		Gegenstand Description Designation Descripcion Designazione Benaemning
01	394 636 40	11	Riegelverschluß	Locking bar
02	542 583 40	1	Motorhaube	Hood
03	542 582 40	1	Motorhaube	Hood
04	542 581 40	1	Motorhaube	Hood
05	542 406 40	1	Motorhaube	Hood
06	542 404 40	1	Motorhaube	Hood
07	542 401 40	1	Motorhaube	Hood
08	542 586 40	1	Motorhaube	Hood
09	542 585 40	1	Motorhaube	Hood
10	*	nB	Dichtprofil	Profiled joint
13	509 789 98	10	Schraube	Screw
14	509 862 98	7	Mutter	Nut
15	510 321 98	6	Scheibe	Washer
16	509 769 98	6	Federring	Lock washer
20	*	1	Anschlagprofil 895mm	Profile
22	551 397 40	4	Klammer	Clamp
23	545 988 40	4	Schraube	Screw
26	*	-	Köderprofil 960mm	Profile joint
-	080 311 40	1	Klebstoff	Adhesive
32	509 775 98	2	Schraube	Screw
33	509 860 98	2	Mutter	Nut
34	340 461 99	2	Scheibe	Washer
37	543 056 40	nB	Klettverschluß 3000mm	Velro fastener
-	543 054 40	1	Dämmatte hinten links	Insulation rear l.h.
-	543 057 40	1	Dämmatte hinten rechts	Insulation rear r.h.
51	542 241 40	1	Rahmen	Frame
52	542 413 40	1	Rahmen	Frame
53	542 410 40	1	Rahmen	Frame
54	542 245 40	1	Rahmen	Frame
55	509 789 98	8	Schraube	Screw
56	509 870 98	8	Mutter	Nut
57	510 321 98	10	Scheibe	Washer
58	542 587 40	6	Ausgleichsscheibe	Shim
59	510 531 98	1	Schraube	Screw
60	509 861 98	1	Mutter	Nut
61	340 506 99	1	Scheibe	Washer
62	542 593 40	1	Kühlerverkleidung	Radiator cowl
63	509 914 98	4	Schraube	Screw
64	509 860 98	4	Mutter	Nut
65	340 461 99	4	Scheibe	Washer

**Verkleidung - Motor
Covering - Engine**

908-1280a

Seite/Page 3 / 4

Bild-Nr Fig Fig Fig Fig Bild nr	ET-Nr Part-No No. de Piece No. de Pieza No. del Pezzo Detalj nr	Stückzahl Qty Qte Ctd Qta Antal	Gegenstand Description Designation Descripcion Designazione Benaemning
--	--	--	---

			* Meterware, bei Bestellung Länge angeben	* Bulk ware, state length required
*	551 394 40	-	Köderprofil	Profile joint
*	551 393 40	-	Anschlagprofil	Profile
*	168 450 40	-	Dichtprofil	Profiled joint

**Verkleidung - Motor
Covering - Engine**

908-1280a

Seite/Page 4 / 4