

908-1700-1

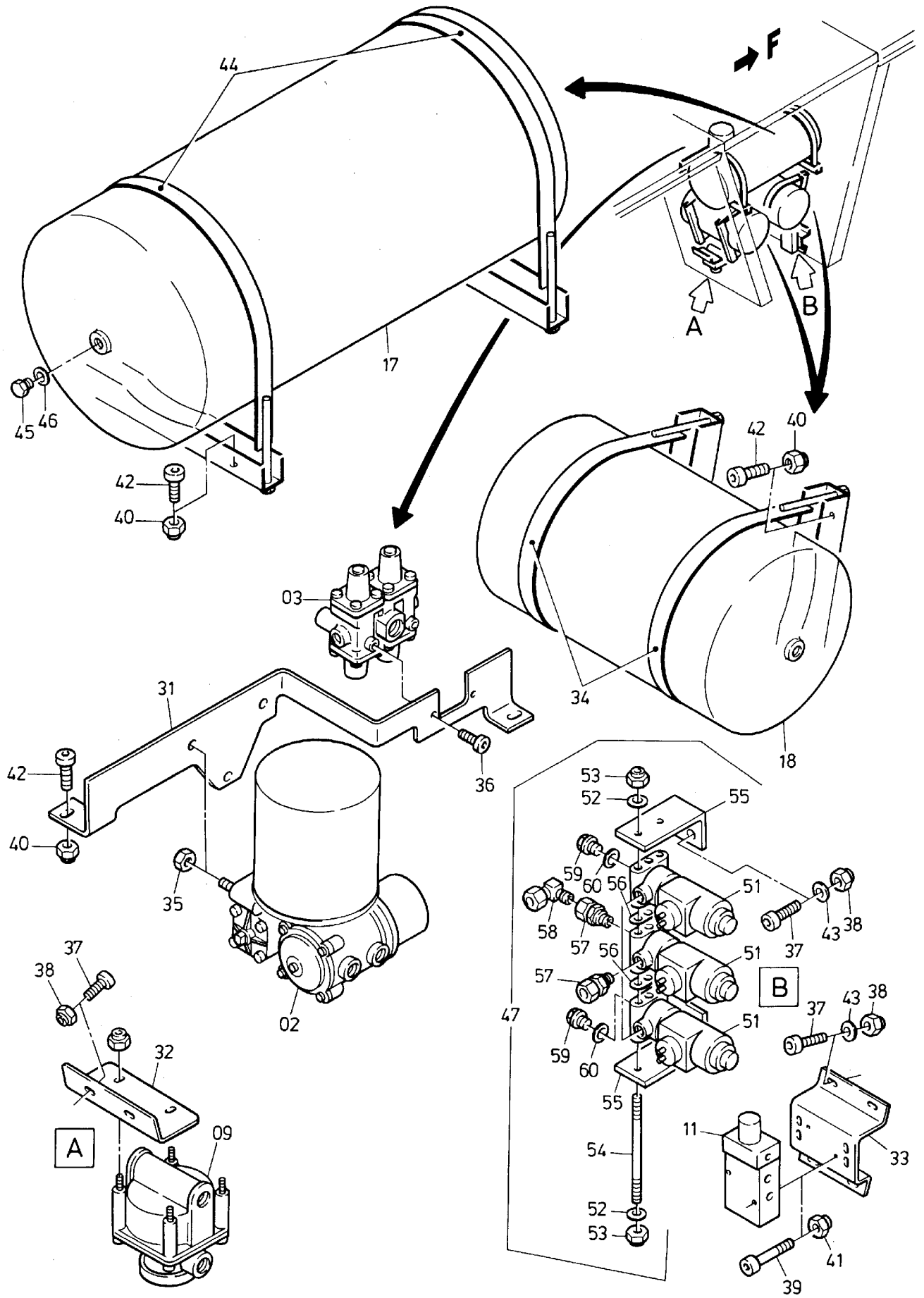

908-1700-1

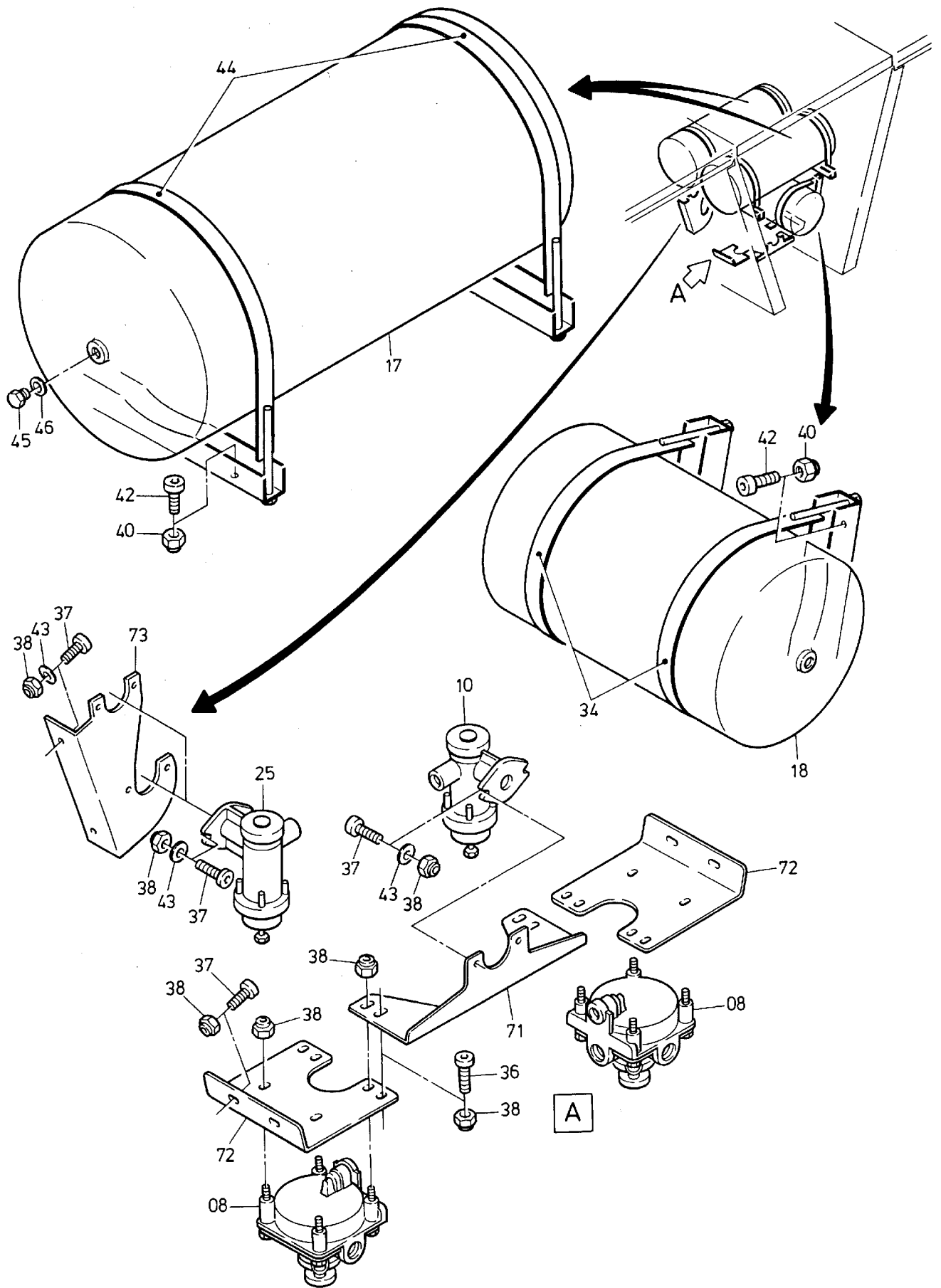

908-1700-1

Bild-Nr Fig Fig Fig Fig Bild nr	ET-Nr Part-No No. de Piece No. de Pieza No. del Pezzo Detailj nr	Stückzahl Qty Qte Ctd Qta Antal		Gegenstand Description Designation Descripcion Designazione Benaemning
01	192 163 40	1	Rückschlagventil	Non-return valve
02	551 150 40	1	Lufttrockner	Air dryer
-	761 176 73	1	Filterelement	Element
03	192 152 40	1	Vierkreisschutzventil	4-Way safety valve
04	224 189 40	1	Bremslichtschalter	Brake light switch
05	324 053 40	1	Bremsventil	Brake valve
06	551 249 40	2	Handbremsventil	Hand brake valve
07	087 257 40	5	Entwässerungsventil	Drain valve
08	551 155 40	2	Relaisventil	Solenoid
09	192 159 40	1	Überlastschutzventil	Overload limiter
10	192 819 40	1	Druckbegrenzungsventil	Pressure relief valve
11	388 713 40	1	Magnetventil	Solenoid valve
12	324 048 40	4	Membranzylinder	Diaphragm cylinder
13	192 156 40	4	Tristopzylinder	Tri stop cylinder
14	387 620 40	2	Tristopzylinder	Tri stop cylinder
15	192 312 40	2	2-Wegeventil	Two-way valve
-	604 489 40	1	3/2-Wegeventil	Two-way valve
16	551 154 40	1	Bremsventil	Brake valve
17	576 199 40	3	Druckluftbehälter 40 l	Compressed-air
18	576 197 40	2	Druckluftbehälter 20 l	Compressed-air
19	546 117 40	1	Druckschalter kpl. 2 bar	Pressure switch assy. 2 bar
20	546 118 40	2	Druckschalter kpl. 2 bar	Pressure switch assy. 2 bar
21	546 119 40	1	Druckschalter kpl. 5 bar	Pressure switch assy. 5 bar
22	192 168 40	3	Prüfanschluß	Test point
23	592 200 40	8	Prüfanschluß	Test point
24	087 415 40	1	Rückschlagventil	Non-return valve
25	180 513 40	2	Druckbegrenzungsventil	Pressure relief valve
31	542 739 40	1	Halter	Retainer
32	542 738 40	1	Halter	Retainer
33	542 728 40	1	Halter	Retainer
34	551 152 40	6	Spannband	Restraining strap
35	509 864 98	3	Mutter	Nut
36	509 787 98	4	Schraube	Screw
37	509 788 98	20	Schraube	Screw
38	509 870 98	30	Mutter	Nut
39	509 785 98	2	Schraube	Screw
40	509 876 98	26	Mutter	Nut
41	509 869 98	2	Mutter	Nut
42	509 794 98	26	Schraube	Bolt
43	510 321 98	10	Scheibe	Washer
44	551 153 40	6	Spannband	Restraining strap
45	509 852 98	2	Verschlußschraube	Screw plug

Bild-Nr Fig Fig Fig Fig Bild nr	ET-Nr Part-No No. de Piece No. de Pieza No. del Pezzo Detailj nr	Stückzahl Qty Qte Ctd Qta Antal		Gegenstand Description Designation Descripcion Designazione Benaemning
46	234 352 40	2	Dichtring	Seal
47	542 816 40	1	Achssteuerung	Axle control
51	207 323 40	3	Magnetventil	Solenoid valve
52	510 321 98	4	Scheibe	Washer
53	509 870 98	4	Mutter	Nut
54	510 086 98	2	Gewindebolzen	Threaded pin
55	542 341 40	2	Halter	Retainer
56	576 132 40	2	Dichtung	Gasket
57	551 617 40	4	Verschraubung	Union
58	551 444 40	1	Verschraubung	Union
59	509 850 98	2	Verschlußschraube	Screw plug
60	192 175 40	2	Dichtring	Seal
71	542 571 40	1	Halter	Retainer
72	542 733 40	2	Halter	Retainer
73	543 460 40		Halter	Retainer