

908-1926

Seite/Page 1 / 3

B

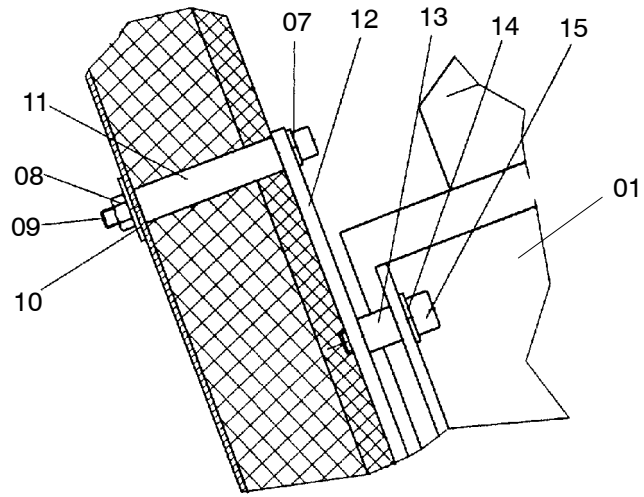

A

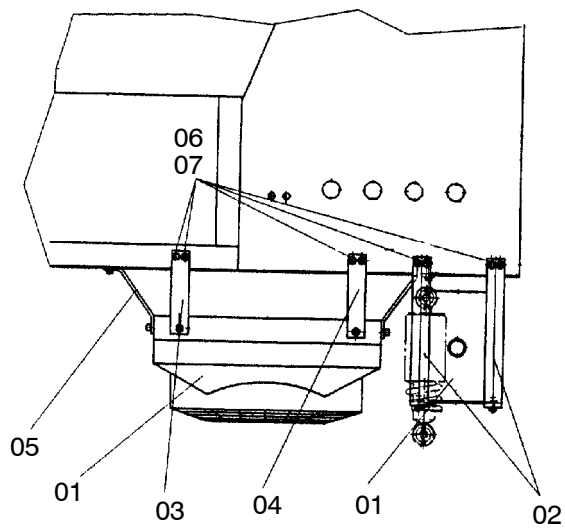

A bei Linksverkehr
for left-hand drive

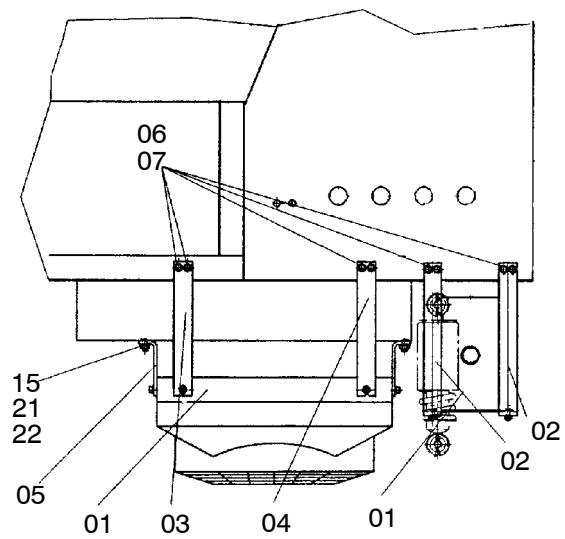

908-1926

Seite/Page 2 / 3

Bild-Nr Fig Fig Fig Fig Bild nr	ET-Nr Part-No No. de Piece No. de Pieza No. del Pezzo Detalj nr	Stückzahl Qty Qte Ctd Qta Antal		Gegenstand Description Designation Descripcion Designazione Benaemning
01	547 491 40	1	Klimaanlage siehe EL-Blatt 993-0261	Air condition see page 993-0261
02	545 970 40	2	Halter	Retainer
03	545 971 40	1	Halter	Retainer
04	545 969 40	1	Halter	Retainer
05	545 967 40	4	Halter	Retainer
06	511 084 98	21	Schraube	Screw
07	340 506 99	36	Scheibe	Washer
08	509 869 98	4	Mutter	Nut
09	510 080 98	4	Schraube	Screw
10	509 879 98	4	Scheibe	Washer
11	546 662 40	4	Rohrstück	Pipe
12	529 152 40	2	Halter	Retainer
13	542 355 40	4	Rohrstück	Pipe
14	509 788 98	4	Schraube	Screw
15	510 321 98	8	Scheibe	Washer
16	547 846 40	1	Abdeckung	Cover
-	576 051 40	2	Durchführungstülle	Bushing socket
18	510 523 98	10	Schraube	Screw
19	*	1	Kantenschutzprofil	Cleat
-	611 960 40	1	Kabelbaum f. Klimaanlage	Harness for air condition
21	510 308 98	4	Schraube	Screw
22	509 870 98	4	Mutter	Nut
			* Meterware, bei Bestellung Länge angeben	* Bulk ware, state length required
*	207 649 40	1	Kantenschutzprofil	Cleat

**Einbau Klimaanlage
Air Condition Arr.**

908-1926

Seite/Page 3 / 3