

909-1205

Seite/Page 1 / 5

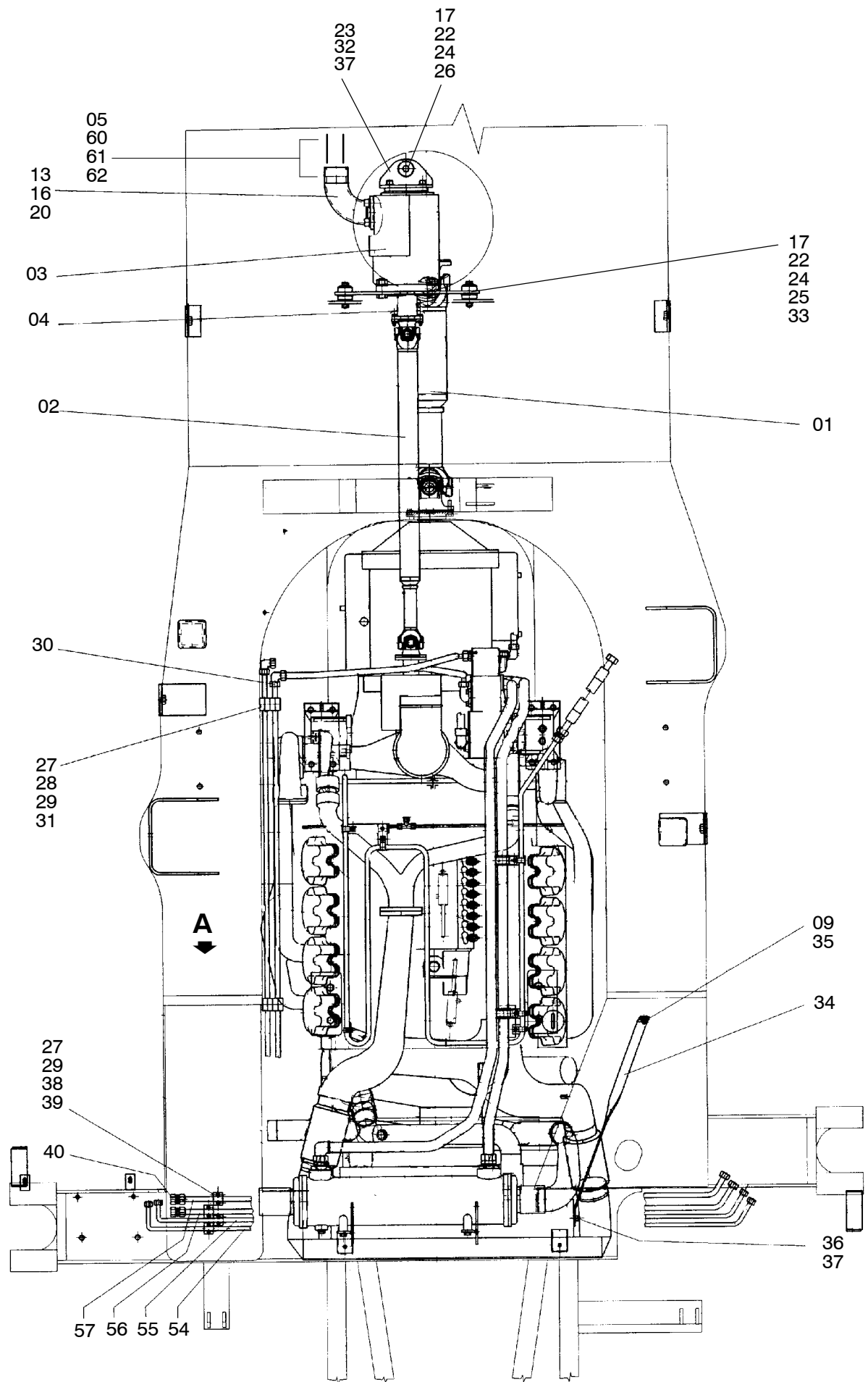

909-1205

Seite/Page 2 / 5

A

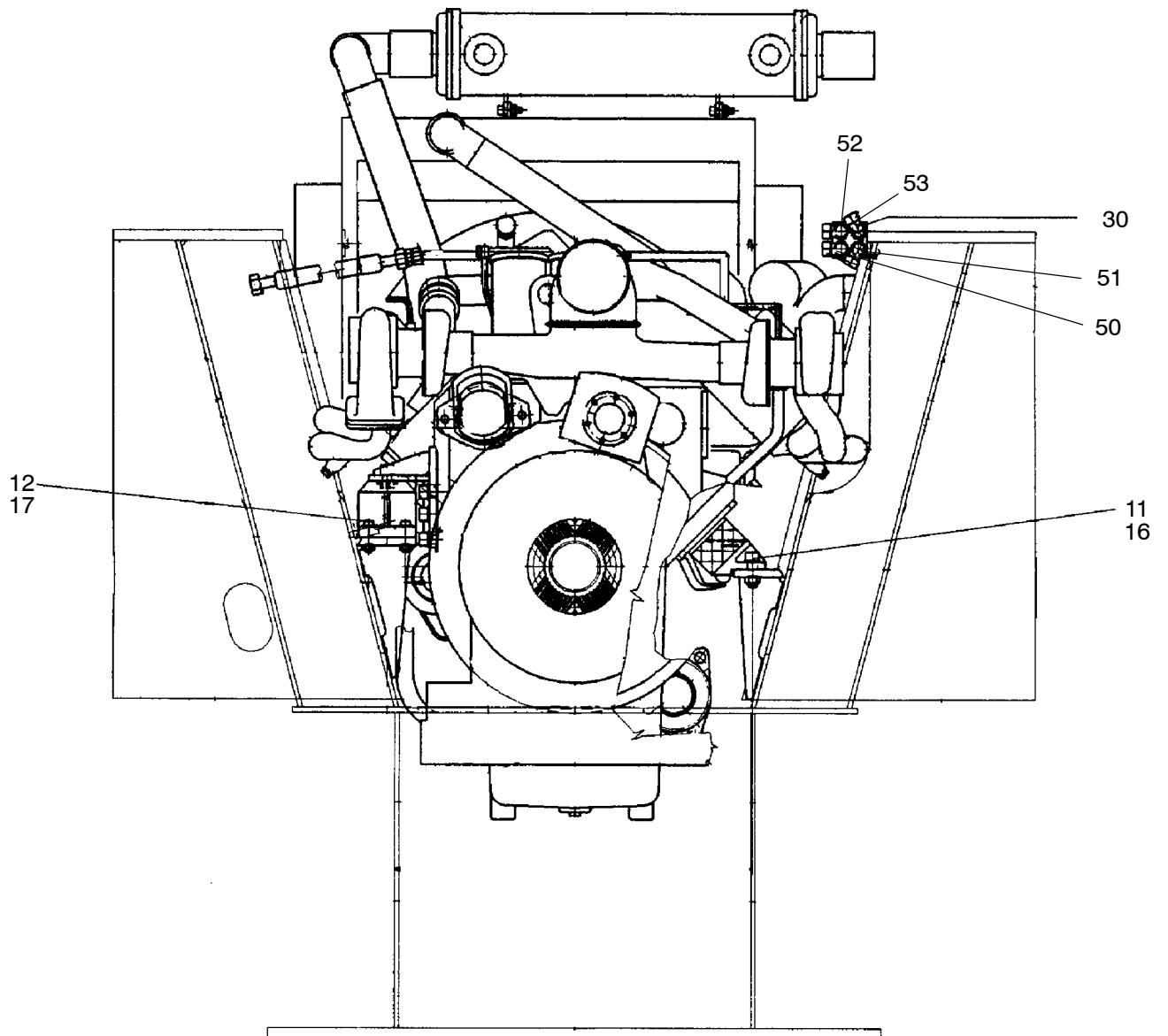

909-1205

Seite/Page 3 / 5

Bild-Nr Fig Fig Fig Fig Bild nr	ET-Nr Part-No No. de Piece No. de Pieza No. del Pezzo Detalj nr	Stückzahl Qty Qte Ctd Qta Antal		Gegenstand Description Designation Descripcion Designazione Benaemning
01	547 293 40	1	Gelenkwelle	Joint shaft
02	547 294 40	1	Gelenkwelle	Joint shaft
03	-	1	Hydr.-Pumpe EL-Blatt 90-3054	Hydr.-pump see page 90-3054
04	546 336 40	1	Gelenkwellenflansch, Pumpe	Joint shaft flange, pump
05	546 787 40	1	Saugstutzen kpl. Bild-Nr. 60-62	Suction tube assy. fig.-no. 60-62
-	388 017 40	2	Schelle	Clamp
-	287 610 40	2	Schelle	Clamp
-	509 877 98	4	Mutter M12, bis 75 040	Nut
-	511 668 98	4	Mutter M14, ab 75 041	Nut M14, from 75 041
09	511 162 98	13	Mutter	Nut
10	511 163 98	12	Schraube	Bolt
11	511 093 98	4	Schraube	Bolt
12	510 209 98	8	Schraube	Bolt
13	510 606 98	4	Schraube	Bolt
14	510 070 98	4	Schraube	Bolt
-	509 907 98	1	Schraube	Bolt
16	510 495 98	8	Scheibe	Washer
17	510 494 98	12	Scheibe	Washer
18	509 908 98	4	Mutter	Nut
19	510 496 98	8	Scheibe	Washer
20	501 543 98	1	O-Ring	O-ring
21	509 829 98	2	Schraube	Bolt
22	509 832 98	3	Schraube	Bolt
23	509 795 98	2	Schraube	Bolt
24	510 183 98	3	Mutter	Nut
25	621 712 40	2	Schwingungsisolator	Shock absorber
26	621 713 40	1	Schwingungsisolator	Shock absorber
27	510 176 98	12	Klemmhälftenpaar	Pair of half clamps
28	510 080 98	8	Schraube	Bolt
29	504 030 98	24	Mutter	Nut
30	509 545 98	4	Stutzen	Socket
31	340 506 99	24	Scheibe	Washer
32	546 717 40	1	Pumpenlager hinten	Pump bearing rear
33	546 716 40	1	Pumpenlager vorne	Pump bearing front
34	546 804 40	1	Zugstab Kühlanlage	Draw bar cooling system
35	510 321 98	1	Scheibe	Washer
36	509 828 98	1	Schraube	Bolt
37	510 314 98	4	Scheibe	Washer
-	174 411 40	10	Kabelbinder	Cable strap

Einbau-Motor, Pumpe und Antriebswellen
Mounting-Engine, Pump and Drive Shafts

909-1205

Seite/Page 4 / 5

Bild-Nr Fig Fig Fig Fig Bild nr	ET-Nr Part-No No. de Piece No. de Pieza No. del Pezzo Detalj nr	Stückzahl Qty Qte Ctd Qta Antal		Gegenstand Description Designation Descripcion Designazione Benaemning
38	509 777 98	16	Schraube	Bolt
39	510 175 40	4	Klemmhälftenpaar	Pair of half clamps
40	509 811 98	2	Stutzen	Socket
41	547 365 40	1	Halter Druck-Zug-Kabel	Retainer push-pull cable
42	509 876 98	1	Mutter	Nut
50	546 750 40	1	Rohrleitung, kpl.	Pipe assy.
51	546 751 40	1	Rohrleitung, kpl.	Pipe assy.
52	546 752 40	1	Rohrleitung, kpl.	Pipe assy.
53	546 753 40	1	Rohrleitung, kpl.	Pipe assy.
54	547 922 40	1	Rohrleitung, kpl.	Pipe assy.
55	547 921 40	1	Rohrleitung, kpl.	Pipe assy.
56	547 920 40	1	Rohrleitung, kpl.	Pipe assy.
57	547 919 40	1	Rohrleitung, kpl.	Pipe assy.
60	543 100 40	1	Saugstutzen	Suction tube
61	546 786 40	1	Schlauchleitung	Hose assy.
62	978 599 73	nB	Dichtring zu Bild-Nr. 61	Seal ring to fig.-no. 61