

siehe Blatt 03
see page 03

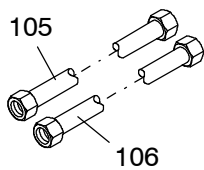

909-1700a1

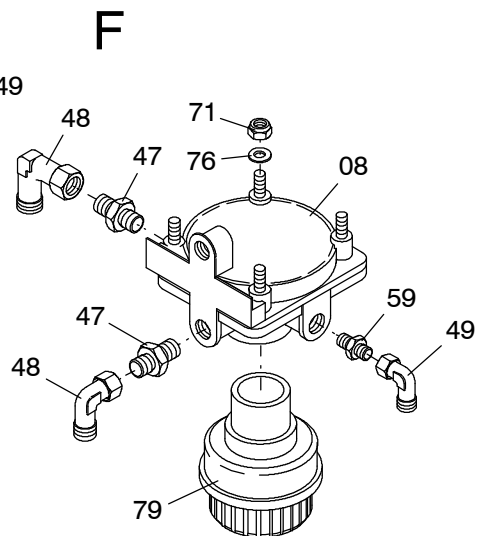
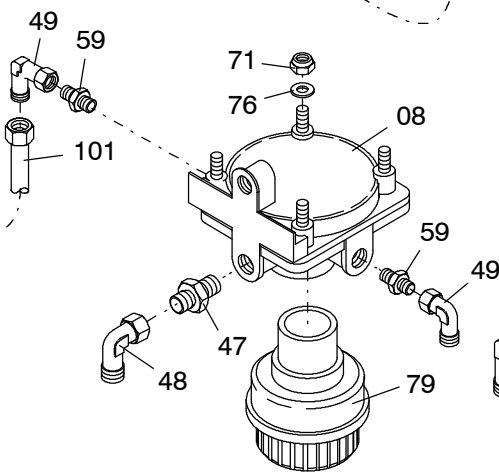
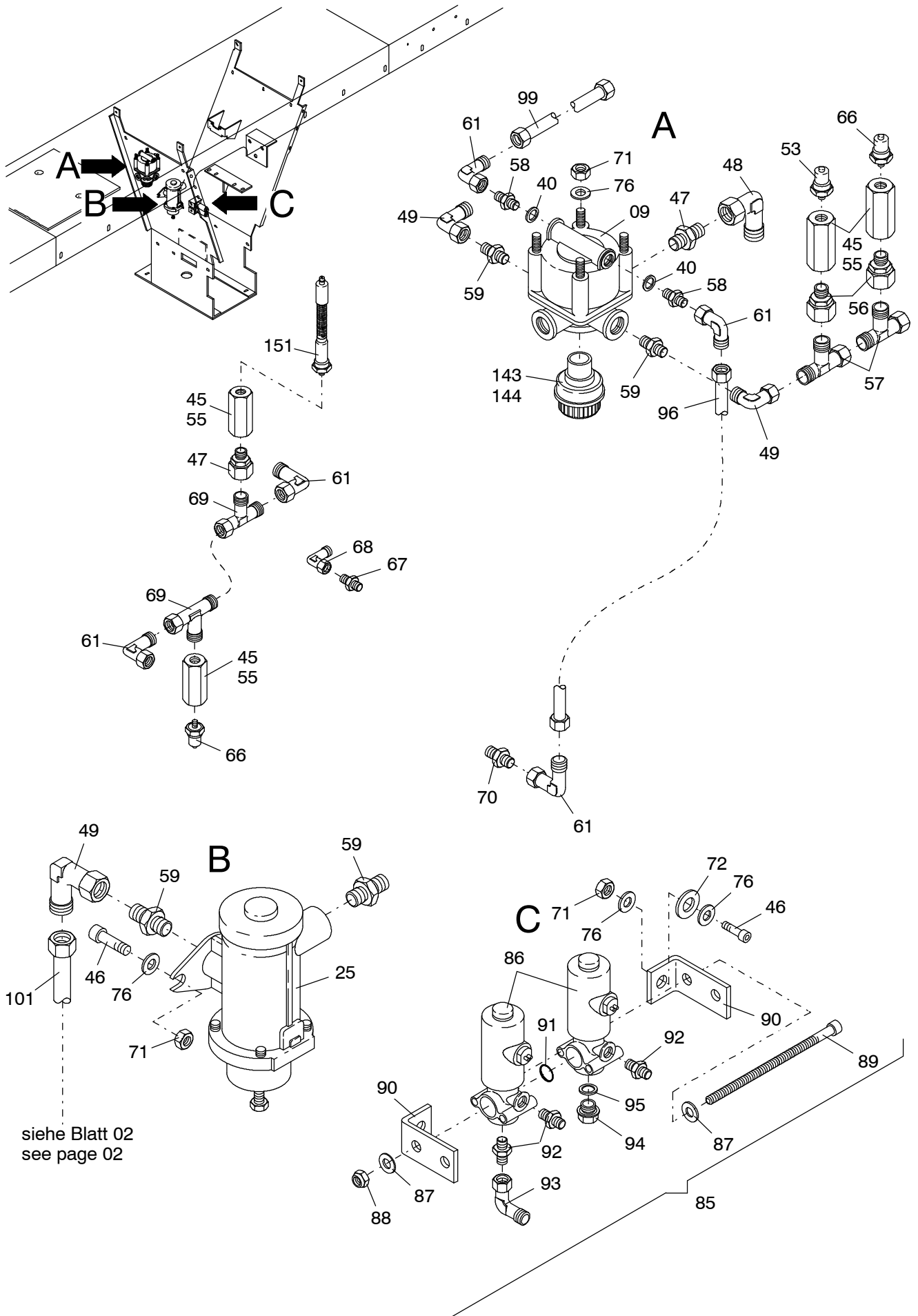

siehe Blatt 02
see page 02

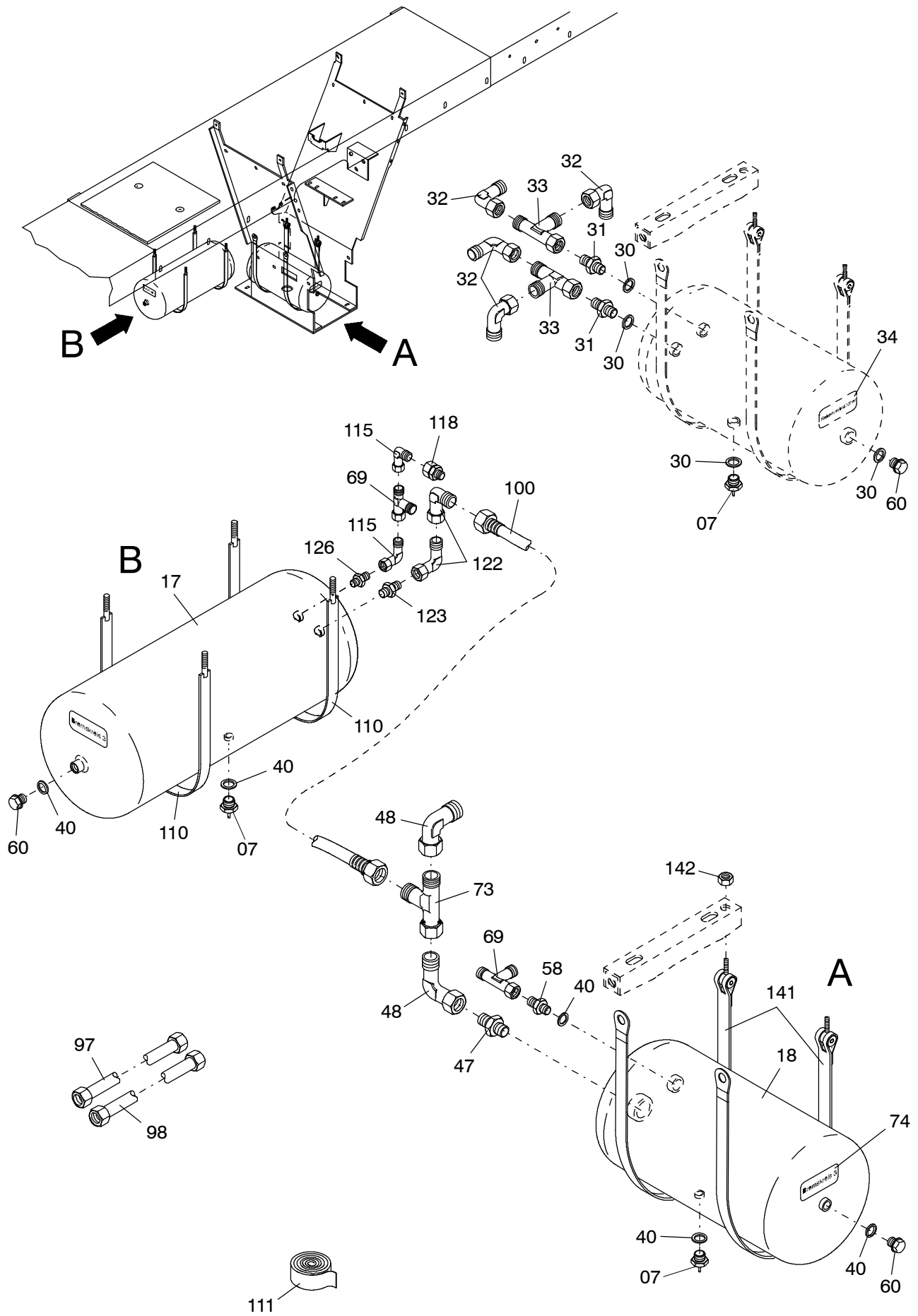

909-1700a1

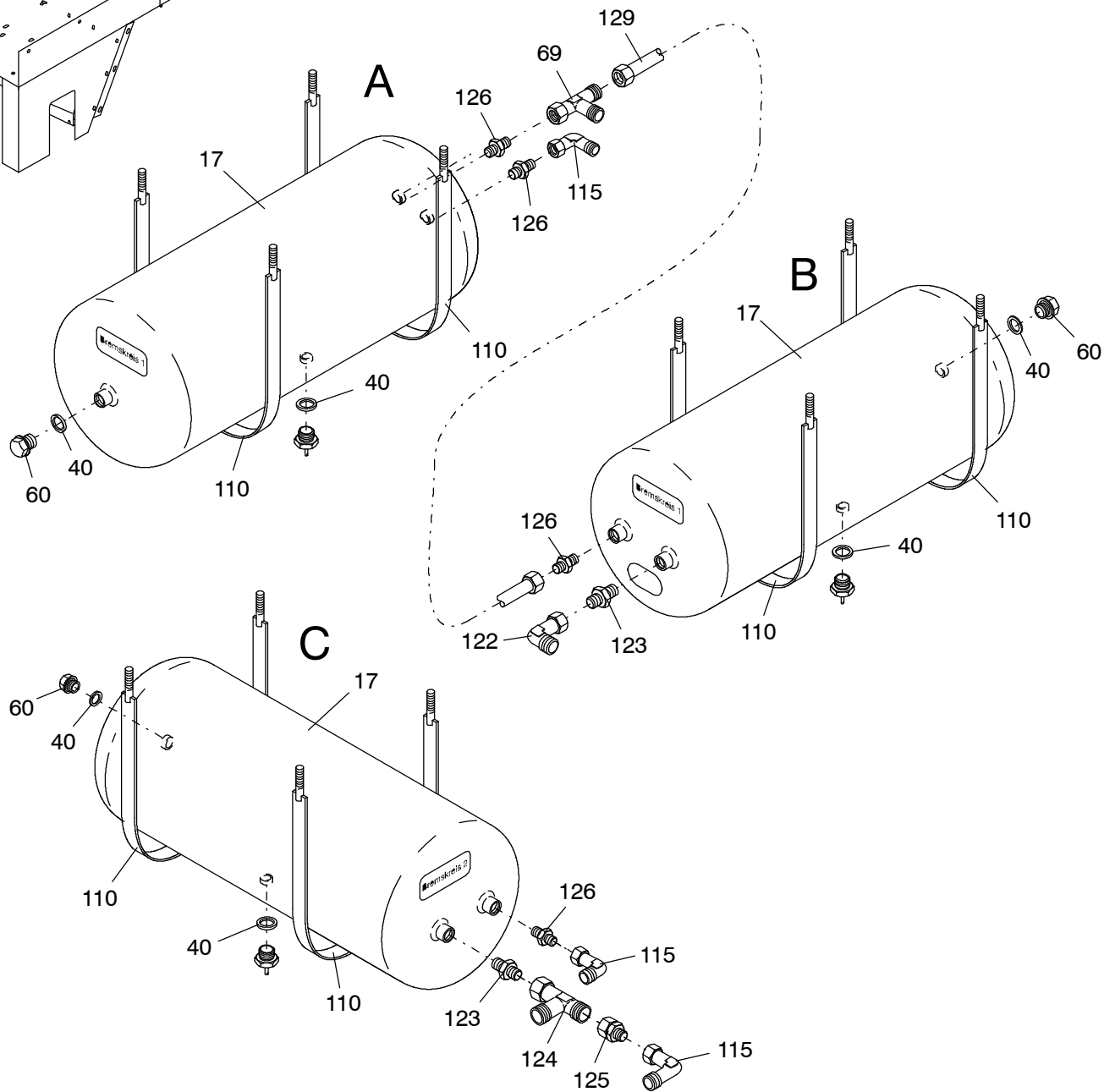
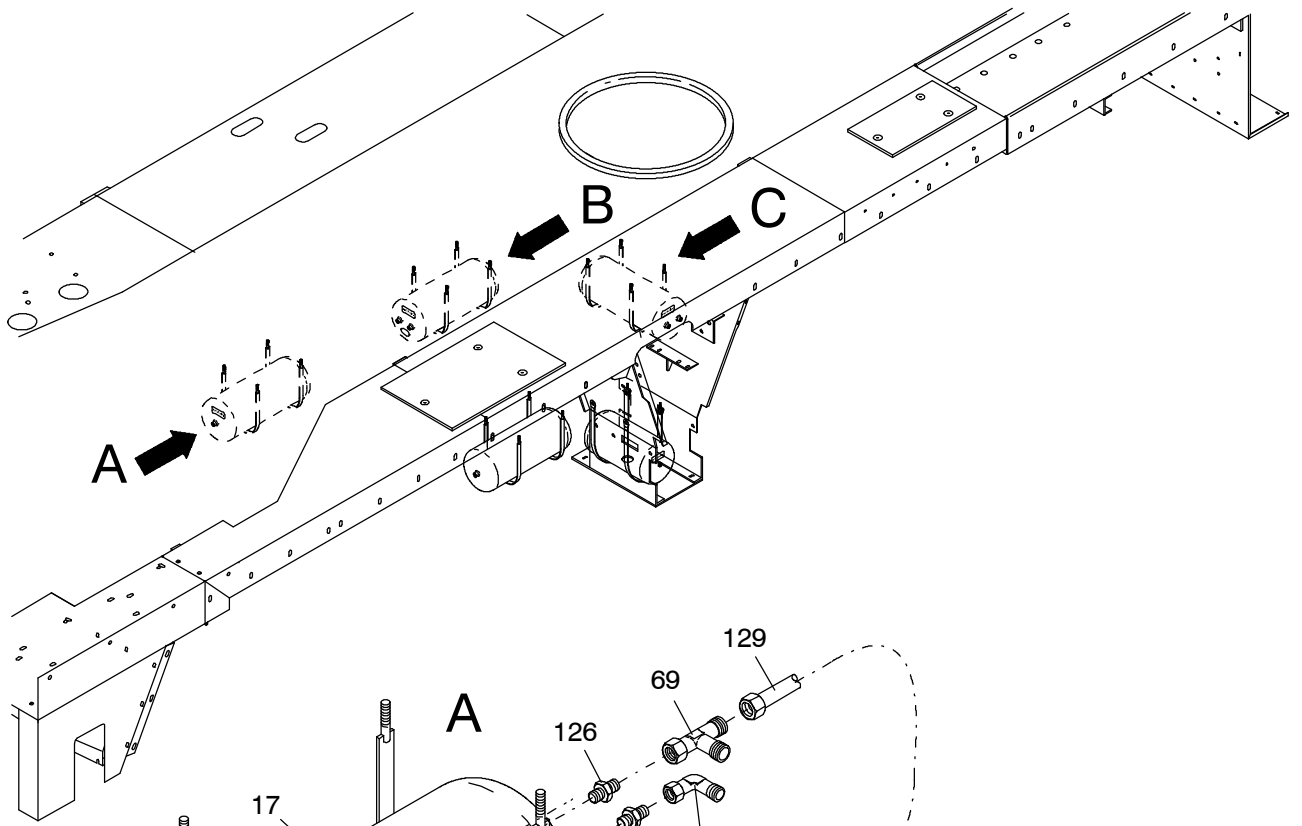

909-1700a1

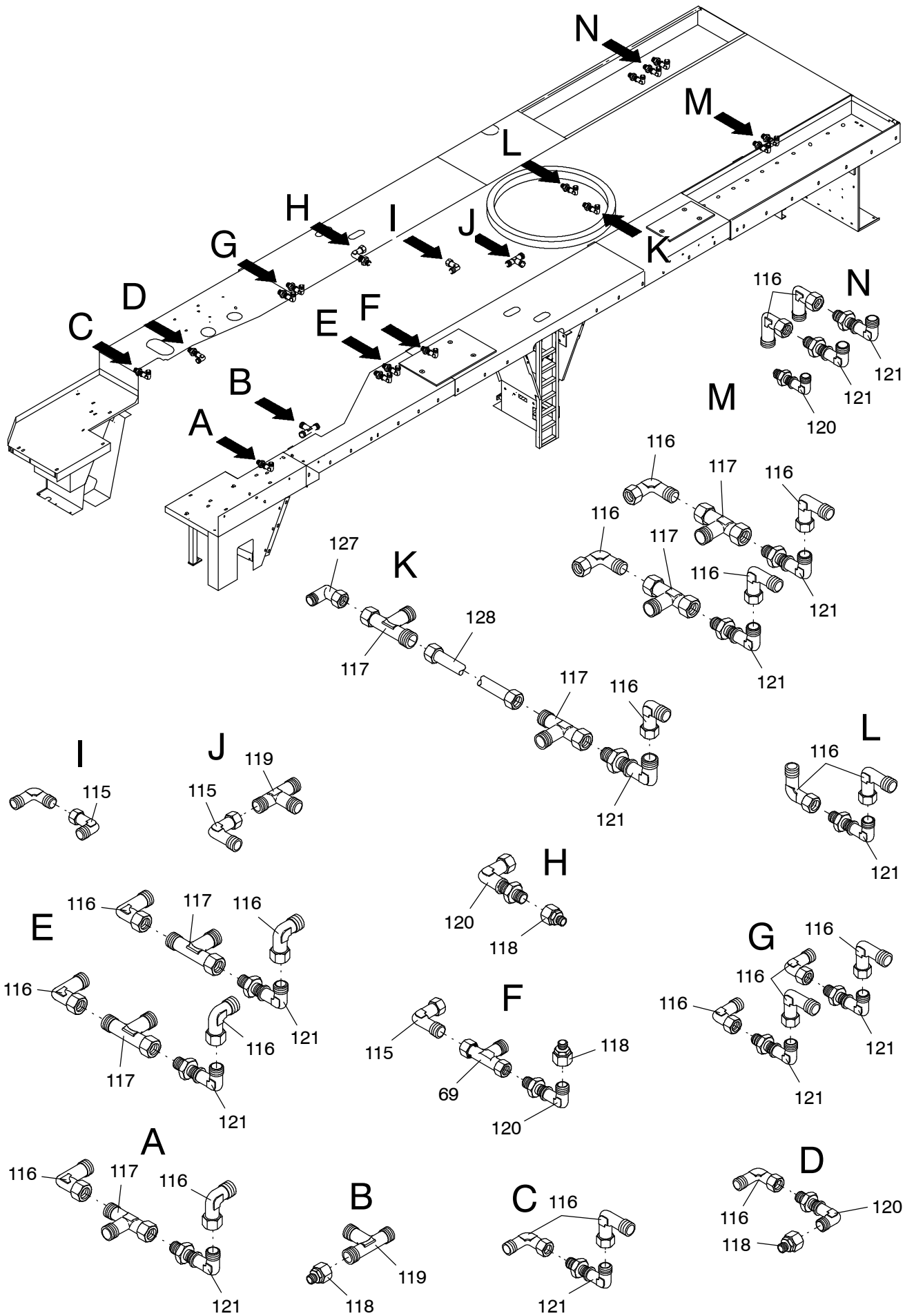

909-1700a1

Bild-Nr Fig Fig Fig Fig Bild nr	ET-Nr Part-No No. de Piece No. de Pieza No. del Pezzo Detalj nr	Stückzahl Qty Qte Ctd Qta Antal		Gegenstand Description Designation Descripcion Designazione Benaeming
01	192 163 40	1	Rückschlagventil	Non-return valve
02	551 150 40	1	Lufttrockner	Air dryer
-	761 176 73	1	Filterelement	Element
03	634 210 40	1	Vierkreisschutzventil	4-Way safety valve
04	224 189 40	1	Bremslichtschalter	Brake light switch
05	324 053 40	1	Bremsventil	Brake valve
06	551 249 40	1	Handbremsventil	Hand brake valve
07	087 257 40	5	Entwässerungsventil	Drain valve
08	551 155 40	2	Relaisventil	Solenoid
09	192 159 40	1	Überlastschutzventil	Overload limiter
10	324 049 40	2	Tristopzylinder	Tri stop cylinder
12	324 048 40	4	Membranzylinder	Diaphragm cylinder
13	256 413 40	4	Tristopzylinder	Tri stop cylinder
14	432 055 40	2	Membranzylinder	Diaphragm cylinder
17	655 066 40	4	Druckluftbehälter 40 l	Compressed-air
18	655 065 40	1	Druckluftbehälter 20 l	Compressed-air
20	388 717 40	1	Druckschalter, kpl. 2bar	Pressure switch, assy. 2bar
21	180 268 40	1	Druckschalter, kpl. 5bar	Pressure switch, assy. 5bar
22	192 168 40	3	Prüfanschluß	Test point
23	592 200 40	10	Prüfanschluß	Test point
25	180 513 40	1	Druckbegrenzungsventil	Pressure relief valve
			Bei Anhängerkupplung zusätzlich Bild-Nr. 26-29	Additionally for trailer coupling fig.-nos. 26-29
26	087 415 40	1	Rückschlagventil	Non-return valve
27	324 097 40	1	Kupplungskopf, rot	Air connection head, red
28	324 098 40	1	Kupplungskopf, gelb	Air connection head, yellow
29	551 161 40	1	Anhängersteuerventil	Control valve
30	234 352 40	4	Dichtring	Seal ring
31	576 057 40	2	Stutzen	Socket
32	551 444 40	4	Stutzen	Socket
33	551 447 40	2	Stutzen	Socket
34	546 417 40	1	Schild "Nebenverbraucher"	Label "Auxiliary consumers"
40	234 352 40	6	Dichtring	Seal ring
41	576 468 40	1	Stutzen	Socket
42	510 494 98	3	Scheibe	Washer
43	576 442 40	1	Stutzen	Socket
44	547 462 40	1	Schlauchleitung	Hose assy.
45	543 986 40	4	Rohrleitung	Pipe assy.
46	509 788 98	4	Schraube	Screw

**Bremsanlage
Brake System**

909-1700a1

Seite/Page 7 / 10

Bild-Nr Fig Fig Fig Fig Bild nr	ET-Nr Part-No No. de Piece No. de Pieza No. del Pezzo Detalj nr	Stückzahl Qty Qte Ctd Qta Antal		Gegenstand Description Designation Descripcion Designazione Benaemning
47	551 451 40	8	Stutzen	Socket
48	551 301 40	8	Stutzen	Socket
49	551 958 40	8	Stutzen	Socket
53	546 119 40	1	Druckschalter, kpl. 5bar	Pressure switch, assy. 5bar
55	551 633 40	4	Verschraubung	Union
56	551 379 40	2	Stutzen	Socket
57	551 380 40	2	Stutzen	Socket
58	576 057 40	3	Stutzen	Socket
59	576 443 40	7	Stutzen	Socket
60	509 852 98	1	Verschlussschraube	Screw plug
61	551 444 40	14	Stutzen	Socket
62	551 609 40	4	Stutzen	Socket
63	192 183 40	4	Dichtring	Seal
64	509 864 98	3	Mutter	Nut
65	509 787 98	6	Schraube	Bolt
66	546 118 40	2	Druckschalter, kpl. 2bar	Pressure switch, assy. 2bar
67	551 634 40	1	Stutzen	Socket
68	551 635 40	1	Stutzen	Socket
69	551 447 40	4	Stutzen	Socket
70	551 617 40	1	Stutzen	Socket
71	509 870 98	10	Mutter	Nut
72	510 314 98	2	Scheibe	Washer
73	551 449 40	1	Verschraubung	Union
74	546 416 40	2	Schild "Bremskreis 3"	Label "Brake circuit 3"
75	592 623 40	1	Verschraubung	Union
76	510 321 98	12	Scheibe	Washer
77	513 045 98	2	Schraube	Bolt
78	340 506 99	4	Scheibe	Washer
79	621 299 40	3	Geräuschdämpfer	Noise absorber
80	509 861 40	1	Mutter	Nut
81	551 349 40	3	Stutzen	Socket
82	287 240 40	1	Führungskappe	Cap
83	654 848 40	1	Steuerblock (für Endriegelung Lenkstange)	Control block (for steering rod end fixing)
85	546 801 40	1	Achssteuerung Bild-Nr.86-95	Axle control fig.-nos.86-95
86	207 323 40	2	Magnetventil, kpl.	Solenoid valve, assy.
87	510 321 98	4	Scheibe	Washer
88	509 870 98	2	Mutter	Nut
89	509 792 98	2	Schraube	Bolt
90	542 341 40	2	Halter	Retainer

**Bremsanlage
Brake System**

909-1700a1

Seite/Page 8 / 10

Bild-Nr Fig Fig Fig Fig Bild nr	ET-Nr Part-No No. de Piece No. de Pieza No. del Pezzo Detalj nr	Stückzahl Qty Qte Ctd Qta Antal		Gegenstand Description Designation Descripcion Designazione Benaemning
91	576 132 40	1	Dichtung	Gasket
92	551 617 40	3	Stutzen	Socket
93	551 444 40	1	Stutzen	Socket
94	509 850 98	1	Verschlußschraube	Screw plug
95	192 175 40	1	Dichtring	Seal ring
96	547 318 40	1	Rohrleitung	Pipe assy.
97	547 570 40	1	Rohrleitung	Pipe assy.
98	547 571 40	1	Rohrleitung	Pipe assy.
99	546 798 40	1	Rohrleitung	Pipe assy.
100	547 320 40	1	Rohrleitung	Pipe assy.
101	543 482 40	1	Rohrleitung	Pipe assy.
105	612 887 40	1	Rohrleitung	Pipe assy.
106	612 888 40	1	Rohrleitung	Pipe assy.
107	547 438 40	1	Rohrleitung	Pipe assy.
110	654 894 40	8	Spannband	Restraining strap
111	*	nB	Gummistreifen	Rubber strap
-	546 414 40	2	Schild "Bremskreis 1"	Label "Brake circuit 1"
-	546 415 40	1	Schild "Bremskreis 2"	Label "Brake circuit 2"
-	546 416 40	1	Schild "Bremskreis 3"	Label "Brake circuit 3"
115	551 444 40	11	Stutzen	Socket
116	551 958 40	21	Stutzen	Socket
117	551 380 40	8	Stutzen	Socket
118	551 615 40	7	Stutzen	Socket
119	509 590 98	2	Verschraubung	Union
120	509 916 98	6	Verschraubung	Union
121	510 328 98	12	Verschraubung	Union
122	551 301 40	3	Stutzen	Socket
123	551 451 40	3	Stutzen	Socket
124	551 449 40	1	Stutzen	Socket
125	551 456 40	1	Stutzen	Socket
126	576 057 40	5	Stutzen	Socket
127	510 537 98	1	Stutzen	Socket
128	543 404 40	1	Rohrleitung (Zusatztank)	Pipe assy.
129	545 296 40	1	Rohrleitung	Pipe assy.
141	654 893 40	2	Spannband	Restraining strap
142	509 861 98	2	Mutter	Nut
143	654 041 40	1	Geräuschdämpfer einschraubbar	Noise absorber to be srewed in
144	287 240 40	1	Führungskappe	Cap
151	546 118 40	1	Druckschalter,kpl. 2bar	Pressure switch,assy. 2bar
152	000 461 12	2	Druckbegrenzungsventil	Pressure relief valve

**Bremsanlage
Brake System**

909-1700a1

Seite/Page 9 / 10

Bild-Nr Fig Fig Fig Fig Bild nr	ET-Nr Part-No No. de Piece No. de Pieza No. del Pezzo Detalj nr	Stückzahl Qty Qte Ctd Qta Antal	Gegenstand Description Designation Descripcion Designazione Benaemning
--	--	--	---

*	527 731 40	-	<p>* Meterware, bei Bestellung Länge angeben</p> <p>* Bulk ware, state length required</p> <p>Gummistreifen weitere Rohrverschraubungen s. EL-Blatt 90-9998, Anhang</p> <p>Rohre s. EL-Blatt 90-9959, Anhang</p> <p>Rohrschellen s. EL-Blatt 90-9995, Anhang</p> <p>Rubber strap further unions see page 90-9998, annex</p> <p>Pipes see page 90-9959, annex</p> <p>Pipe clamps see page 90-9995, annex</p>
---	------------	---	---