

909-1910

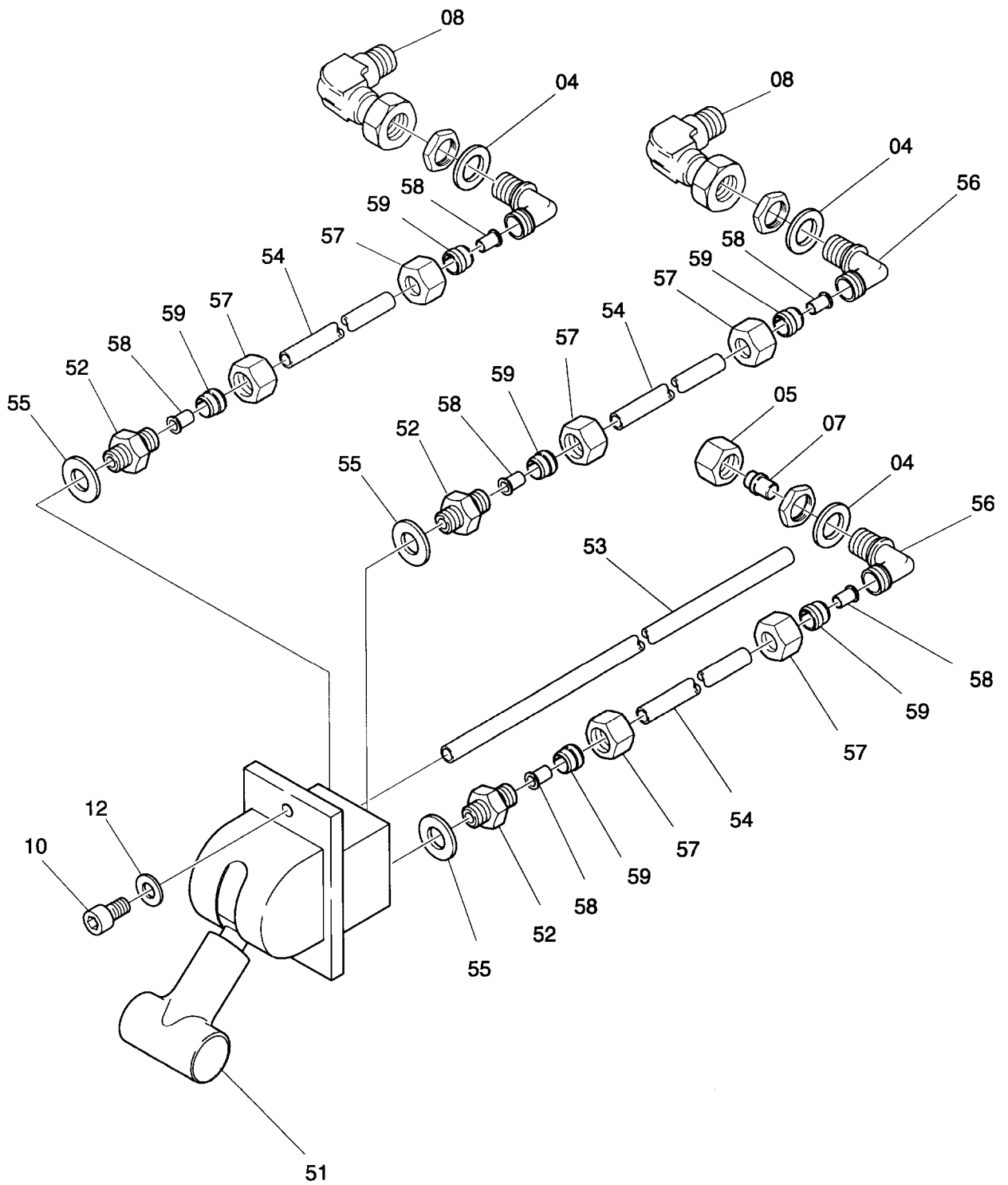

909-1910

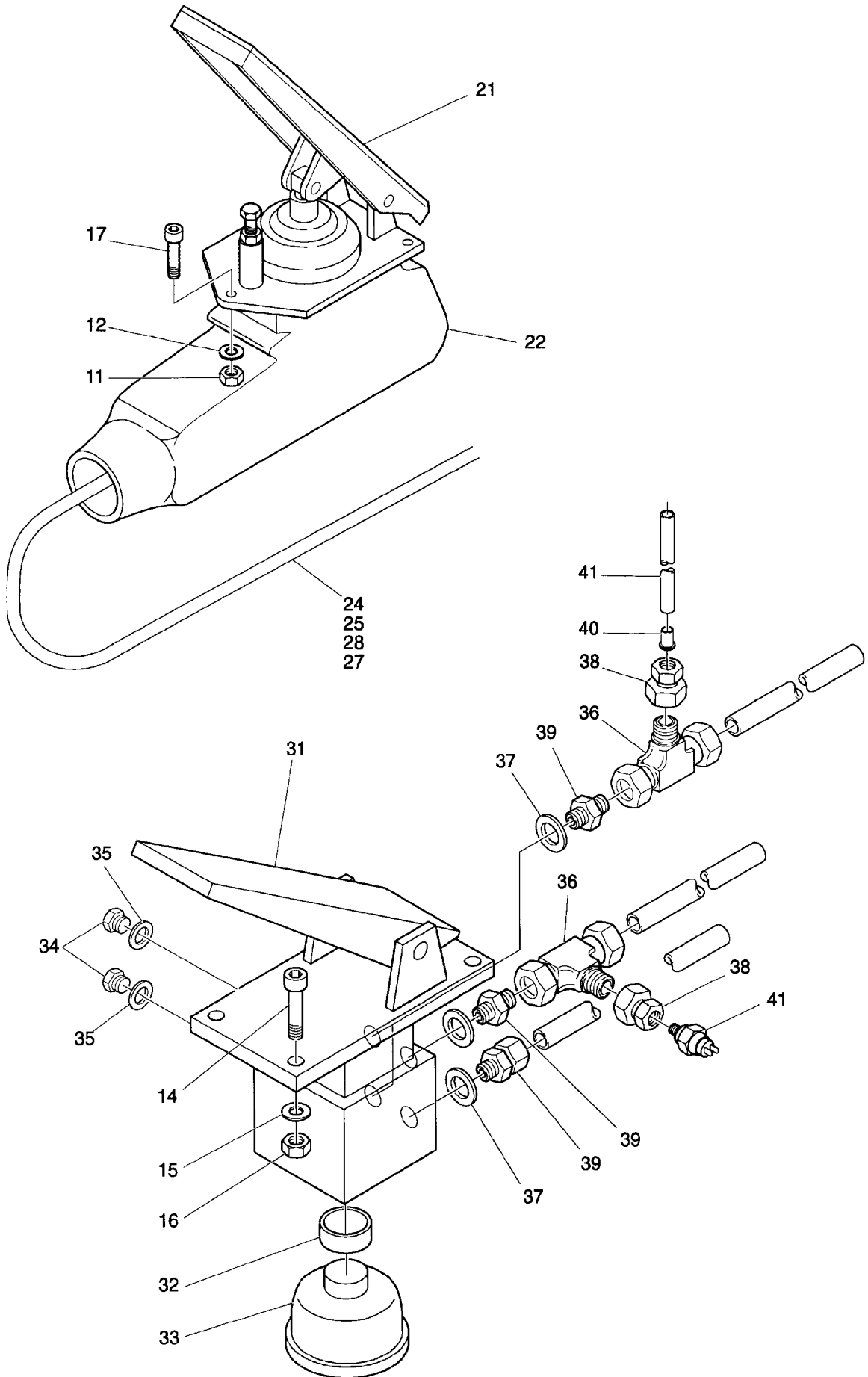

909-1910

Bild-Nr Fig Fig Fig Fig Bild nr	ET-Nr Part-No No. de Piece No. de Pieza No. del Pezzo Detailj nr	Stückzahl Qty Qte Ctd Qta Antal		Gegenstand Description Designation Descripcion Designazione Benaemning
01	551 214 40	1	Gaspedal kpl. Bild-Nr. 21-25	Accelerator pedal assy. fig-nos. 21-25
02	542 294 40	1	Fußbremsventil kpl. Bild-Nr. 31-42	Pedal oper. brake valve assy. fig-nos. 31-42
03	542 295 40	1	Handbremsventil kpl. Bild-Nr. 51-59	Hand brake valve assy. fig-nos. 51-59
04	510 495 98	3	Scheibe	Washer
05	509 807 98	1	Überwurfmutter	Union nut
07	509 892 98	1	Verschraubung	Union
08	551 444 40	3	Verschraubung	Union
10	509 777 98	4	Schraube	Screw
11	509 869 98	3	Mutter	Nut
12	340 506 99	3	Scheibe	Washer
14	509 788 98	4	Schraube	Screw
15	510 321 98	4	Scheibe	Washer
16	509 870 98	4	Mutter	Nut
17	509 778 98	3	Schraube	Screw
21	244 651 40	1	Fußpedal	Pedal
22	244 652 40	1	Schutzhülle	Protective hose
24	576 139 40	1	Gaszug 2700 mm	Accelerator cable
25	551 213 40	1	Kugelpfanne	Ball cup
27	509 775 98	2	Schraube	Screw
28	506 000 98	1	Sicherungsbügel	Safety bow
31	324 053 40	1	Bremsventil	Brake valve
32	432 190 40	1	Entlüftungsteil	Breather part
33	287 241 40	1	Geräuschkämpfer	Noise absorber
34	509 850 98	2	Verschlußschraube	Plug
35	192 175 40	2	Dichtung	Seal
36	551 447 40	4	Stutzen	Socket
37	192 183 40	4	Dichtring	Seal ring
38	551 615 40	3	Stutzen	Socket
39	551 609 40	3	Stutzen	Socket
40	007 575 98	4	Hülse	Sleeve
41	224 189 40	1	Bremslichtschalter	Brake light switch
42	542 612 40	2	Rohrleitung ø 6x2000	Pipe assy.
51	551 249 40	1	Handbremsventil	Hand brake valve
52	551 609 40	3	Verschraubung	Union
53	*	nB	Schlauch	Hose
54	*	nB	Kunststoffrohr ø 10	Plastic pipe
55	192 183 40	3	Dichtring	Seal ring
56	509 916 98	3	Verschraubung	Union
57	509 807 98	6	Überwurfmutter	Union nut

**Bedienelemente  
Control Units**

**909-1910**

Seite/Page 4/5

Bild-Nr Fig Fig Fig Fig Bild nr	ET-Nr Part-No No. de Piece No. de Pieza No. del Pezzo Detailj nr	Stückzahl Qty Qte Ctd Qta Antal		Gegenstand Description Designation Descripcion Designazione Benaemning
58	007 577 98	6	Hülse	Sleeve
59	159 966 40	6	Klemmring	Clamping ring
64	543 234 40	1	Konsole kpl. Bild-Nr. 81-88	Console assy. fig-nos. 81-88
65	500 890 98	6	Blechschraube	Tapping screw
70	542 339 40	1	Scheibe	Washer
71	551 344 40	1	Stopkabel mit Griff 2000 mm	Shut-off cable with handle
81	543 233 40	1	Armaturenblech	Instrument board panel
82	543 248 40	1	Wegeventil	Directional spool valve
83	592 084 40	1	Drehschalter	Turn switch
84	592 083 40	2	Verschraubung	Union
85	551 038 40	1	Tastenkippschalter	Push-toggle switch
86	363 422 40	1	Symbol für Schalter	Symbol for switch
87	979 378 73	1	Glühbirne	Bulb
88	*	nB	Kunststoffrohr ø 4	Plastic pipe
91	621 744 40	1	Fahrschalter	Drive switch
92	621 745 40	1	Relaisbox	Relay box
93	510 523 98	7	Schraube	Bolt
94	340 506 99	14	Scheibe	Washer
95	509 869 98	7	Mutter	Nut
96	546 718 40	1	Halter	Retainer
			* Meterware, bei Bestellung Länge angeben	* Bulk ware, state length required
*	255 367 40	-	Schlauch	Hose
*	501 502 98	-	Kunststoffrohr ø 4	Plastic pipe
*	501 019 98	-	Kunststoffrohr ø 10	Plastic pipe
<b>Bedienelemente</b>			<b>909-1910</b>	
<b>Control Units</b>			Seite/Page 5/5	