

910-1005-1

Seite/Page 1 / 5

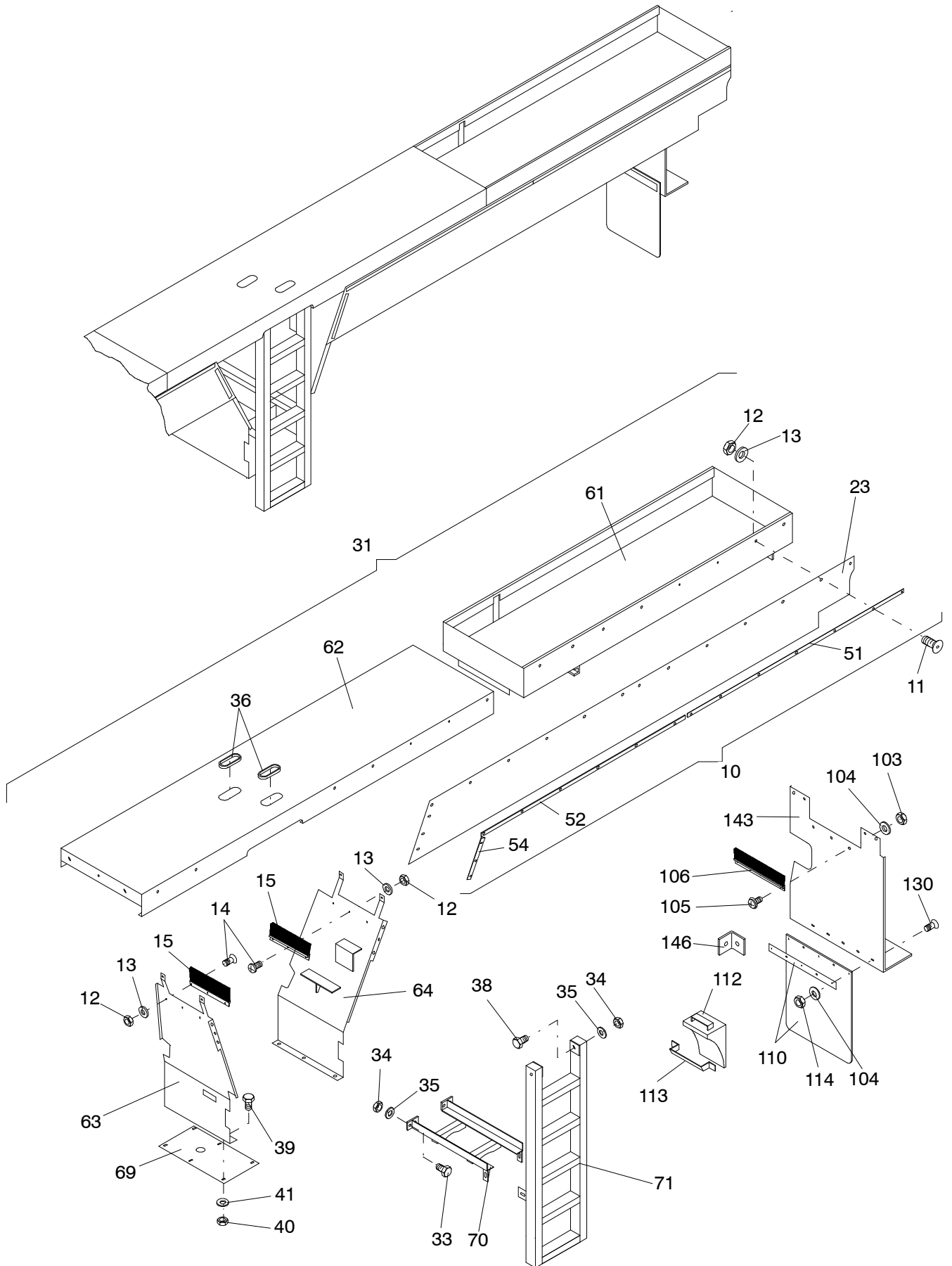

910-1005-1

Seite/Page 2 / 5

Bild-Nr Fig Fig Fig Fig Bild nr	ET-Nr Part-No No. de Piece No. de Pieza No. del Pezzo Detalj nr	Stückzahl Qty Qte Ctd Qta Antal		Gegenstand Description Designation Descripción Designazione Benaemning
01	547 621 40	1	Verkleidung links kpl. Bild-Nr. 31-44	Covering l.h. assy. fig-nos. 31-44
03	509 833 98	14	Schraube	Bolt
04	510 495 98	14	Scheibe	Washer
05	511 197 98	4	Schraube	Bolt
06	510 494 98	4	Scheibe	Washer
07	510 208 98	2	Schraube	Bolt
08	509 876 98	2	Mutter	Nut
09	510 314 98	4	Scheibe	Washer
10	547 483 40	1	Leiste, Bild-Nr. 51-56	Strip, fig-nos. 51-56
11	511 260 98	47	Senkschraube	Countersunk screw
12	509 870 98	58	Mutter	Nut
13	510 321 98	56	Scheibe	Washer
14	509 759 98	8	Linsen-Flansch-Schraube	Fillister-head screw
15	547 625 40	2	Bürstenleiste	Brush strip
16	542 657 40	1	Geradstellungsanzeige kpl. Bild-Nr. 81-85	Inclination indicator assy. fig-nos. 81-85
17	509 778 98	3	Schraube	Screw
18	509 869 98	3	Mutter	Nut
19	340 506 99	3	Scheibe	Washer
-	208 851 40	nB	Anti-Dröhn-Masse	Anti rumple mass
21	672 008 40	1	Schürze	Protection cover
22	547 612 40	1	Schürze	Protection cover
23	547 611 40	1	Schürze	Protection cover
31	547 411 40	1	Verkleidung links Bild-Nr. 61-71	Covering l.h. fig-nos. 61-71
32	547 425 40	1	Werkzeugkiste	Tool box
-	592 023 40	1	Hebelverschluß zu Bild 32	Fastener to fig. no 32
33	509 830 98	21	Schraube	Bolt
34	510 183 98	25	Mutter	Nut
35	510 494 98	35	Scheibe	Washer
36	*	-	Kantenschutz, L=400	Header
38	510 209 98	4	Schraube	Bolt
39	509 940 98	6	Schraube	Bolt
40	509 870 98	10	Mutter	Nut
41	510 321 98	14	Scheibe	Washer
42	509 759 98	4	Linsen-Flansch-Schraube	Fillister-head screw
43	509 831 98	2	Schraube	Bolt
44	509 790 98	4	Schraube	Screw
51	546 344 40	1	Leiste	Strip
52	547 487 40	1	Leiste	Strip

**Verkleidung, links
Covering, L.H.**

910-1005-1

Seite/Page 3 / 5

Bild-Nr Fig Fig Fig Fig Bild nr	ET-Nr Part-No No. de Piece No. de Pieza No. del Pezzo Detalj nr	Stückzahl Qty Qte Ctd Qta Antal		Gegenstand Description Designation Descripcion Designazione Benaemning
53	547 484 40	1	Leiste	Strip
54	547 485 40	4	Leiste	Strip
55	547 492 40	1	Leiste	Strip
56	547 493 40	1	Leiste	Strip
57	672 009 40	1	Leiste	Strip
58	672 011 40	1	Winkel	Angle
59	509 790 98	1	Schraube	Screw
61	547 412 40	1	Verkleidung, hinten	Covering, rear
62	547 413 40	1	Verkleidung, mitte	Covering, center
63	547 414 40	1	Kotflügel, vorne	Fender, front
64	547 415 40	1	Kotflügel, hinten	Fender, rear
65	547 416 40	1	Verkleidung, vorne	Covering, front
66	547 417 40	1	Abdeckblech, vorne	Cover plate, front
67	547 418 40	1	Rahmen, vorne	Frame, front
68	547 419 40	1	Leiter, vorne	Ladder, front
69	547 424 40	1	Bodenblech Aufstieg	Bottom plate ladder
70	547 427 40	1	Konsole mit Spannband	Console with strap retainer
71	546 237 40	1	Leiter, mitte	Ladder, center
81	099 423 40	1	Dosenlibelle	Box level
82	455 439 40	1	Schutzkappe	Protection cap
83	542 656 40	1	Libellenhalter	Box level bracket
84	509 803 98	3	Schraube	Screw
85	509 859 98	9	Mutter	Nut
103	509 870 98	52	Mutter	Nut
104	510 321 98	86	Scheibe	Washer
105	509 759 98	21	Linsenflansch-Schraube	Fillister-head screw
106	547 625 40	1	Bürstenleiste	Brush strip
110	613 905 40	2	Schmutzfänger	Dirt trap
112	243 649 40	2	Unterlegkeil	Chock
113	243 648 40	2	Unterlegkeilhalter	Retaining device for chock
114	509 869 98	68	Mutter	Nut
115	340 506 98	88	Scheibe	Washer
116	509 759 98	16	Linsenflansch-Schraube	Fillister-head screw
120	510 209 98	3	Schraube	Bolt
121	510 183 98	5	Mutter	Nut
122	510 494 98	5	Scheibe	Washer
123	509 830 98	2	Schraube	Bolt
130	510 207 98	20	Flachrundschrabe	Screw
131	614 022 40	1	Leiterauiage	Ladder supporting surface
132	614 313 40	1	Tür	Door
133	614 314 40	1	Schallschutz	Noise insulation

**Verkleidung, links
Covering, L.H.**

910-1005-1

Seite/Page 4 / 5

Bild-Nr Fig Fig Fig Fig Bild nr	ET-Nr Part-No No. de Piece No. de Pieza No. del Pezzo Detalj nr	Stückzahl Qty Qte Ctd Qta Antal		Gegenstand Description Designation Descripcion Designazione Benaemning
134	511 742 98	1	Schraube	Screw
135	509 940 98	5	Schraube	Screw
136	350 766 99	2	Scheibe	Washer
141	547 426 40	1	Schutzblech	Guard plate
142	547 428 40	1	Schutzblech	Guard plate
143	547 429 40	1	Schutzblech	Guard plate
144	613 414 40	1	Deckel	Cover
145	613 789 40	1	Winkel	Anlge
146	614 019 40	1	Winkel	Angle
151	180 206 40	1	Federriegel	Twist lock
152	315 092 00	2	Schraube	Screw
153	332 351 99	3	Mutter	Nut
154	431 014 73	2	Schanier	Hinge
			* Meterware, bei Bestellung Länge angeben	* Bulk ware, state length required
*	167 693 40	-	Kantenschutz, L=400	Header

Verkleidung, links
Covering, L.H.

910-1005-1

Seite/Page 5 / 5