

910-1915c

Seite/Page 1 / 3

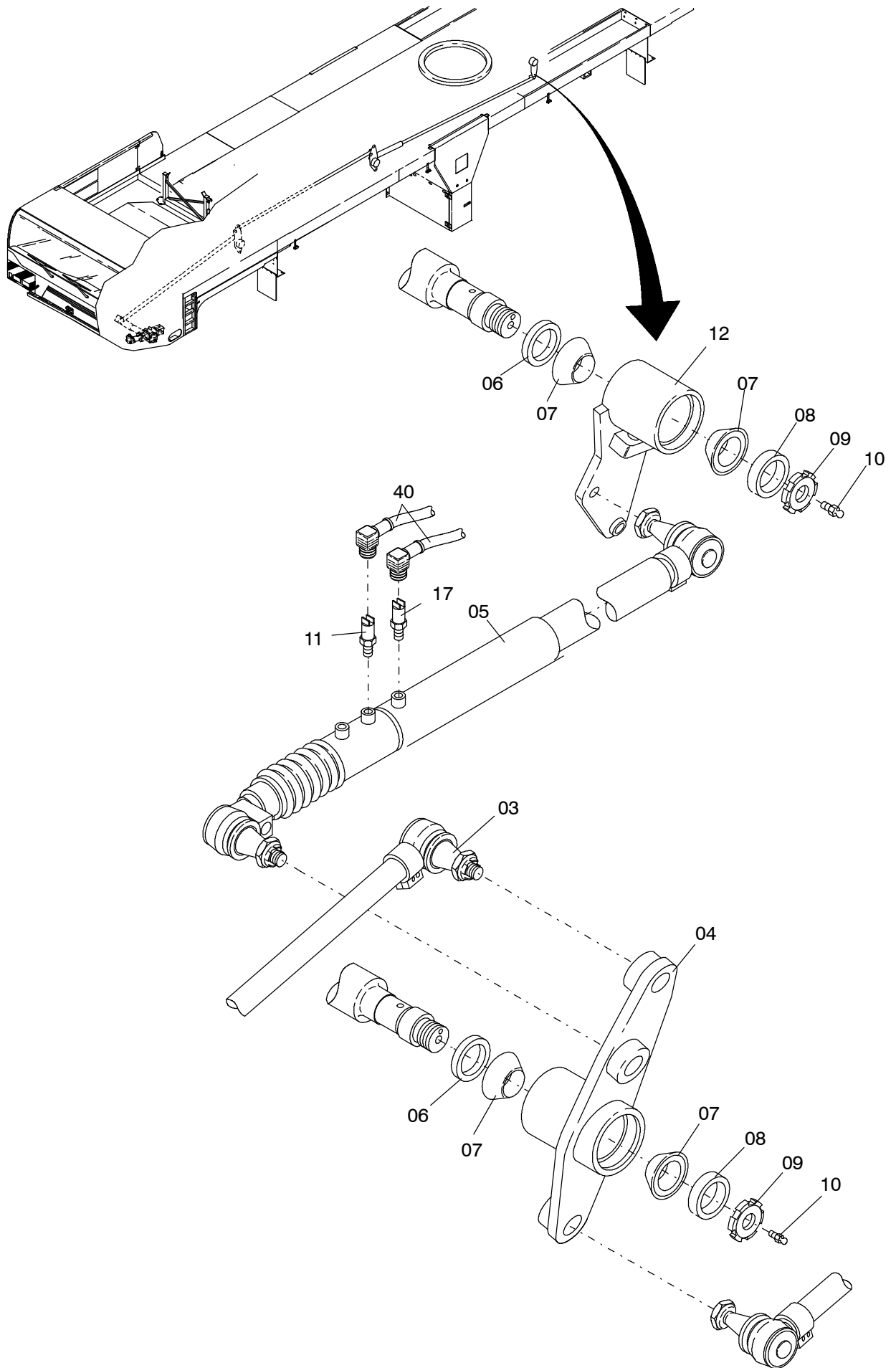

910-1915c

Seite/Page 2 / 3

Bild-Nr Fig Fig Fig Bild nr	ET-Nr Part-No No. de Piece No. de Pieza No. del Pezzo Detalj nr	Stückzahl Qty Qte Ctd Qta Antal		Gegenstand Description Designation Descripcion Designazione Benaemning
01	547 331 40	1	Lenkstange	Steering rod
02	547 478 40	1	Lenkhebel	Steering lever
03	547 335 40	1	Lenkstange	Steering rod
04	672 584 40	1	Lenkhebel	Steering lever
05	000 165 12	1	Hydr. Lenkstange s. EL-Blatt 993-0459	Hydr. steering rod see page 993-0459
06	450 618 40	3	Laufscheibe	Spacer
07	450 616 40	6	Schräggelenklager	Pivot bearing
08	450 617 40	3	Wellenscheibe	Spacer
09	450 619 40	3	Nutmutter	Groove nut
10	350 561 99	3	Kegelschmiernippel	Grease nipple
11	621 786 40	1	Näherungsschalter, schliesser	Induction switch, N.O.
12	672 585 40	1	Lenkhebel	Steering lever
13	192 526 40	1	Lenkstockhebel	Strut rod
14	509 816 98	4	Schraube	Bolt
15	547 280 40	1	Halbblock einschl. Bild 21-25	Semi-integral steering gear incl. fig. no 21-25
16	634 490 40	1	Stutzen	Socket
17	621 787 40	1	Näherungsschalter, öffener	Induction switch, N.C.
21	515 526 40	1	Halbblock Hydrolenkung s. EL-Blatt 90-3071	Semi-integral power steering gear see page 90-3071
22	551 531 40	6	Stutzen	Socket
23	551 483 40	6	Stutzen	Socket
24	551 480 40	2	Stutzen	Socket
25	604 411 40	2	Stutzen	Socket
40	420 470 12	2	Initiator-Kabel, l=5m	Initiator cable, l=5m

**Lenkungseinbau, mech.
Mountig of Steering Assy.**

910-1915c

Seite/Page 3 / 3