

**949-2140**

Seite/Page 1 / 3

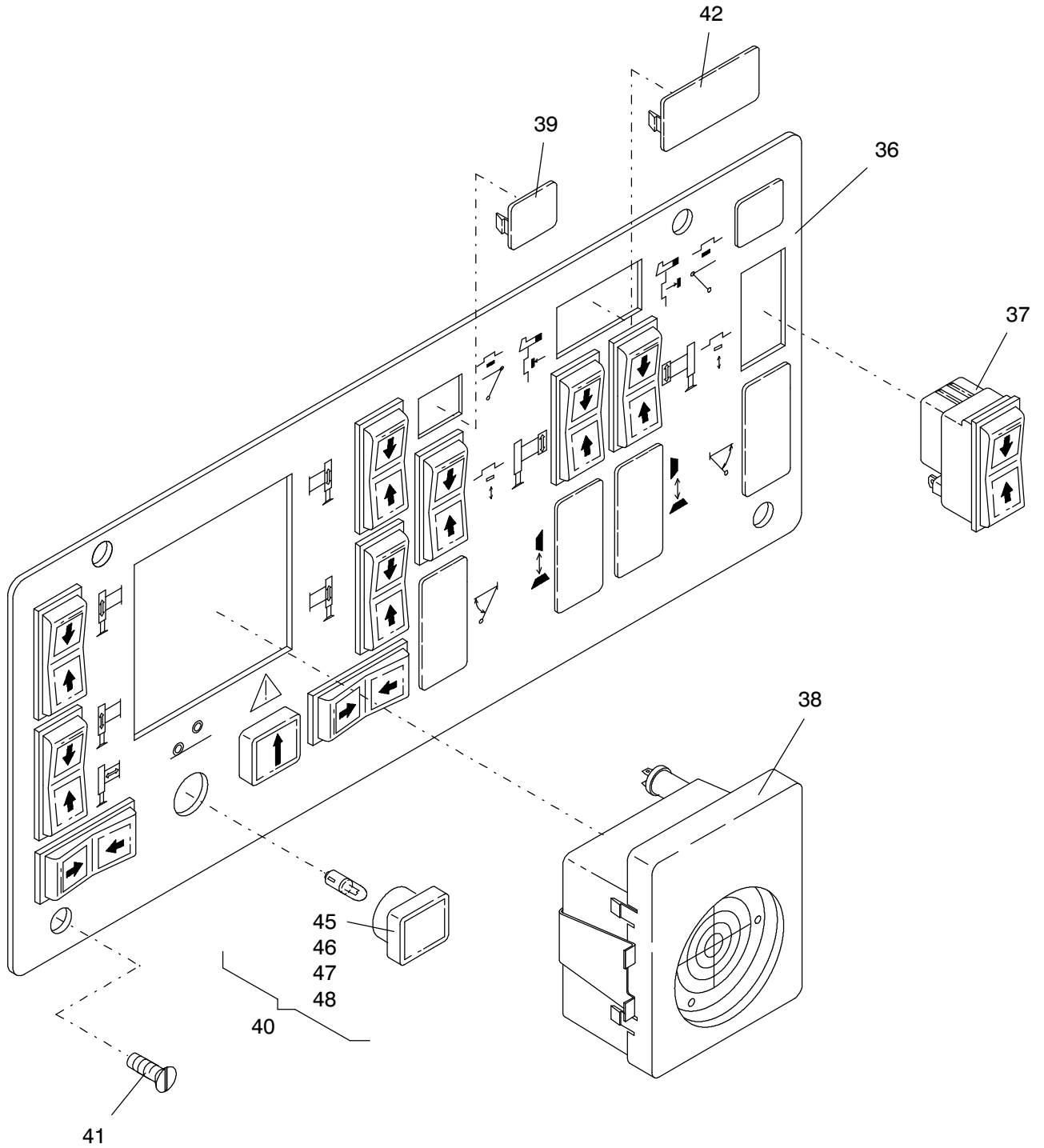

Bild-Nr Fig Fig Fig Fig Bild nr	ET-Nr Part-No No. de Piece No. de Pieza No. del Pezzo Detalj nr	Stückzahl Qty Qte Ctd Qta Antal		Gegenstand Description Designation Descripcion Designazione Benaemning
00	131 896 12	1	Bedienkasten, rechts kpl.	Operation box assy. R.H.
01	131 344 12	1	Leergehäuse	Housing
03	635 836 40	16	Abstandsbolzen	Distance pin
05	001 933 12	1	Gabelkopf	Shoe
06	001 935 12	1	Gasfeder	Gas operated positioner
07	634 034 40	1	Schlauchverschraubung	Union
08	634 032 40	-	Kabelschutzwelle Länge angeben	Cable protection pipe state length required
09	634 036 40	1	Dichtung	Gasket
10	323 693 40	2	Kabelverschraubung	Cable union
11	307 639 99	4	Schraube	Screw
12	509 870 98	4	Mutter	Nut
13	340 628 99	8	Scheibe	Washer
15	125 333 99	4	Schraube	Screw
16	318 372 99	4	Schraube	Screw
17	348 635 40	4	Blindnietmutter	Blind rivet nut
18	551 003 40	8	Blindnietmutter	Blind rivet nut
19	001 934 12	1	Abstandsbolzen	Distance pin
21	000 301 12	4	Distanzhülse	Distance sleeve
23	131 342 12	1	Blech	Metal sheet
24	343 852 99	2	Federring	Lock washer
25	510 875 98	2	Mutter	Nut
26	340 461 99	2	Scheibe	Washer
29	207 615 40	8	Federring	Lock washer
35	131 897 12	1	Armaturenbrett kpl.	Dash board assy.
36	131 382 12	1	Armaturenbrettblech	Dash board
37	420 359 12	10	Leuchtschalter	Switch
38	420 307 12	1	Dosenlibelle	Box level
39	001 000 12	2	Blindplatte	Blank plate
40	001 421 12	2	Leuchttaster	Luminous key switch
41	318 293 99	4	Schraube	Bolt
42	002 169 12	5	Blindplatte	Blank plate
45	460 124 12	2	Druckhaube	Push hood
46	460 123 12	2	Sprungschaltelement	Quick-break switch element
47	460 125 12	2	Leuchtdrucktasten-Vorsatz	Luminous touch contact adapter
48	356 156 40	2	Glühlampe	Bulb

**Bedienkasten, rechts**  
**Operation box, R.H.**

**949-2140**

Seite/Page 3 / 3