

970-1200g

Seite/Page 1 / 5

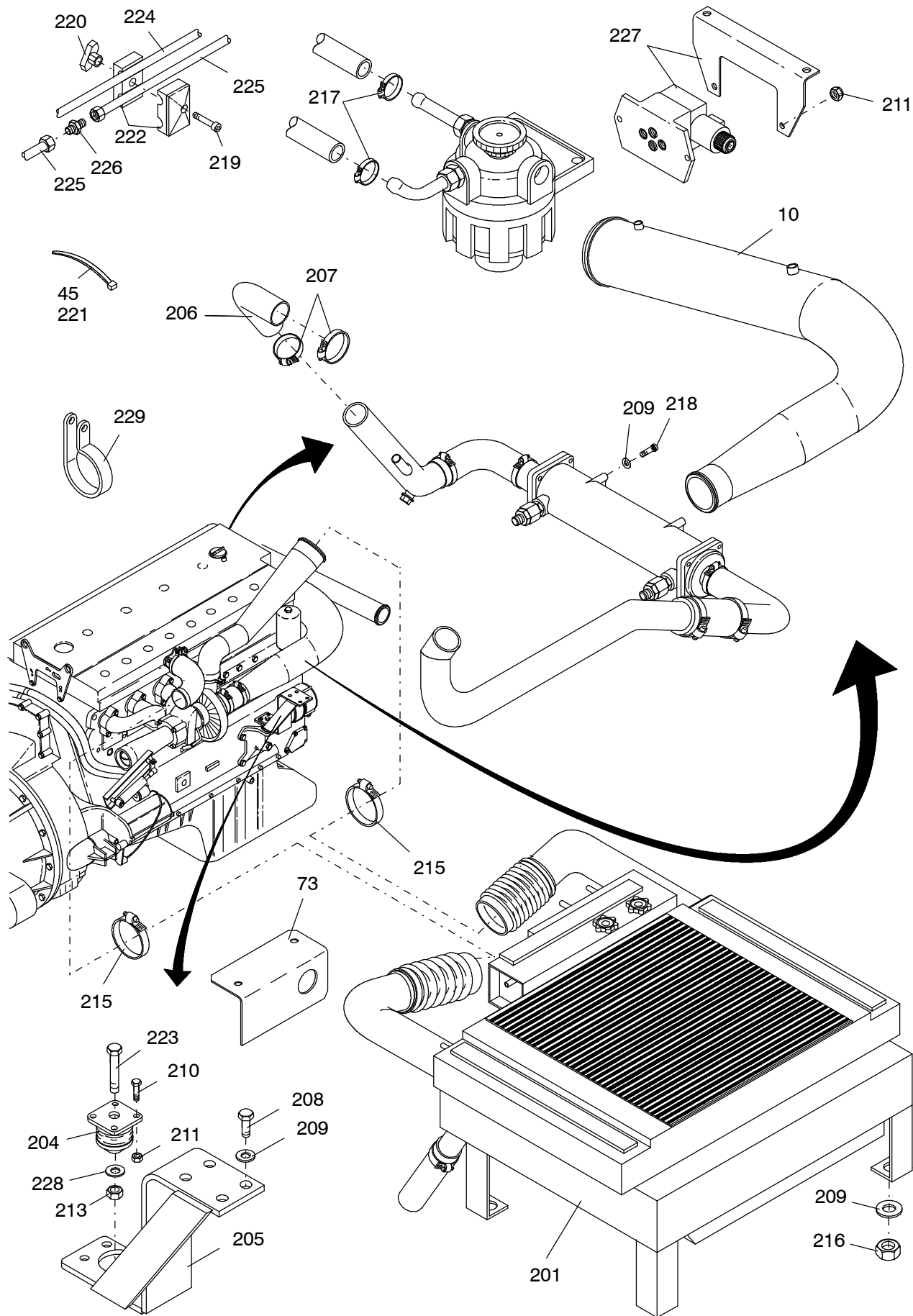

970-1200g

Seite/Page 2 / 5

Bild-Nr Fig Fig Fig Fig Bild nr	ET-Nr Part-No No. de Piece No. de Pieza No. del Pezzo Detalj nr	Stückzahl Qty Qte Ctd Qta Antal		Gegenstand Description Designation Descripcion Designazione Benaemning
01	001 717 12	1	Dieselmotor s. EL-Blatt 993-1076	Diesel engine see page 993-1076
02	001 718 12	1	Getriebe s. EL-Blatt 993-1077	Gear box see page 993-1077
03	670 449 40	1	Elektrik Motor s. EL-Blatt 970-2100, etc.	Electric engine see page 970-2100, etc.
04	672 808 40	1	Rohr	Pipe
05	672 799 40	1	Rohr	Pipe
06	673 349 40	1	Rohr	Pipe
07	000 495 12	1	O-Ring	O-Ring
08	000 496 12	1	O-Ring	O-Ring
09	542 793 40	1	Schlauchkrümmer	Foam hose
10	673 978 40	1	Ansaugrohr	Suction pipe
12	000 503 12	1	Klemmschelle	Clamp
13	000 504 12	1	Klemmschelle	Clamp
14	673 964 40	1	Gelenkwelle	Joint shaft
15	001 509 12	1	Hydr. Pumpe s. EL-Blatt 993-0934	Hydr. pump see page 993-0934
16	001 571 12	1	Zahnradpumpe s. EI-Blatt 993-0988	Gear type pump see page 993-0988
17	672 819 40	1	Getriebekonsole	Gear box console
18	255 239 40	1	Flächendichtung	Fluid sealing
19	288 928 40	2	Schlauschelle	Hose clamp
20	509 877 98	4	Mutter	Nut
21	654 387 40	1	Wegeventil	Directional spool valve
22	592 048 40	1	Stutzen	Socket
23	551 635 40	1	Stutzen	Socket
24	551 616 40	1	Stutzen	Socket
25	551 444 40	1	Stutzen	Socket
28	509 870 98	6	Mutter	Nut
29	542 341 40	1	Halter Motorsteuerung	Retainer
30	319 261 99	12	Schraube	Bolt
31	510 314 98	12	Scheibe	Washer
32	151 194 99	4	Gewindebohrung	Thread bush
33	000 792 12	4	Mutter	Nut
34	007 503 98	2	Schraube	Screw
35	510 494 98	2	Scheibe	Washer
36	490 282 40	1	Schlauch 90°	Hose 90°
37	295 442 40	4	Schlauschelle	Hose clamp
38	673 677 40	1	Schlauch	Hose
39	000 575 12	1	Saugstutzen	Suction socket

Bild-Nr Fig Fig Fig Fig Bild nr	ET-Nr Part-No No. de Piece No. de Pieza No. del Pezzo Detalj nr	Stückzahl Qty Qte Ctd Qta Antal		Gegenstand Description Designation Descripcion Designazione Benaemning
40	654 774 40	1	Stutzen	Socket
41	308 438 99	11	Schraube	Bolt
42	510 316 98	11	Scheibe	Washer
43	551 616 40	1	Stutzen	Socket
44	654 775 40	1	Stutzen	Socket
45	056 292 40	10	Kabelband	Cabel strip
47	192 147 40	1	Schlauch	Hose
48	511 169 98	1	Stutzen	Socket
49	551 531 40	1	Stutzen	Socket
50	551 480 40	1	Stutzen	Socket
51	551 404 40	1	Stutzen	Socket
52	287 609 40	2	Schlauchschele, ø32-50	Hose clamp, ø32-50
54	551 681 40	2	Stutzen	Socket
55	576 471 40	2	Stutzen	Socket
58	303 061 12	1	Rohr Ø 28	Pipe Ø 28
59	303 063 12	1	Rohr Ø 28	Pipe Ø 28
60	303 059 12	1	Stutzen	Socket
61	514 010 98	8	Schraube	Bolt
62	510 686 98	6	Schraube	Bolt
63	673 056 40	1	Halter	Retainer
64	509 794 98	4	Schraube	Bolt
65	510 314 98	5	Scheibe	Washer
66	673 366 40	1	Halter Verrohrung	Retainer pipes
67	510 354 98	4	Schelle	Clamp
68	509 797 98	1	Schraube	Bolt
69	673 088 40	1	Rohr	Pipe
70	551 680 40	2	Stutzen	Socket
73	302 547 12	1	Schutzblech Klappenbremse	Protection plate
76	303 062 12	1	Rohr Ø 28	Pipe Ø 28
80	302 658 12	1	Halter	Retainer
81	001 184 12	-	Gummistreifen	Rubber strip
82	295 517 40	1	Schlauchschele	Hose clamp
83	506 957 98	4	Schraube	Screw
87	542 326 40	1	Halter	Retainer
88	509 869 98	4	Mutter	Nut
89	340 506 99	4	Scheibe	Washer
90	551 510 40	1	Stutzen	Socket
101	673 256 40	1	Öleinfüller	Oil filler
102	001 137 12	1	Schraubstutzen	Screw socket
103	339 932 99	1	Dichtring	Seal
104	673 266 40	1	Schlauch	Hose assy.

Bild-Nr Fig Fig Fig Bild nr	ET-Nr Part-No No. de Piece No. de Pieza No. del Pezzo Detalj nr	Stückzahl Qty Qte Ctd Qta Antal		Gegenstand Description Designation Descripcion Designazione Benaemning
105	287 609 40	2	Schlauchschelle	Hose hose
106	509 869 98	2	Mutter	Nut
107	340 506 99	2	Scheibe	Washer
201	672 735 40	1	Kühlanlage siehe EL-Blatt 970-1235, etc.	Cooling system see page 970-1235, etc.
203	192 144 40	2	Gummipuffer	Rubber puffer
204	432 387 40	2	Gummipuffer	Rubber puffer
205	672 836 40	1	Motorlager links	Mounting left
206	542 793 40	1	Schlauchkrümmer	Hose elbow
207	288 928 40	2	Schlauchschelle	Hose clip
208	510 716 98	4	Schraube	Bolt
209	510 316 98	12	Scheibe	Washer
210	509 820 98	16	Schraube	Bolt
211	509 876 98	8	Mutter	Nut
212	509 835 98	2	Schraube	Bolt
213	510 109 98	4	Mutter	Nut
215	300 723 40	2	Schlauchschelle	Hose clamp
216	510 183 98	4	Mutter	Nut
217	287 608 40	5	Schlauchschelle	Hose clip
218	000 846 12	4	Schraube	Bolt
219	509 777 98	7	Schraube	Screw
220	504 030 98	7	Mutter	Nut
221	056 292 40	20	Kabelband	Cable strap
222	513 671 98	7	Klemmhälftenpaar	Pair of half clamps
223	308 423 99	2	Schraube	Bolt
224	673 074 40	1	Rohr Ø 18 kpl.	Pipe assy.
225	673 077 40	1	Rohr Ø 18 kpl.	Pipe assy.
226	511 169 98	1	Stutzen	Socket
227	673 075 40	1	Lüftersteuerung s. EL-Blatt 970-1810, etc.	Fan control see page 970-1810, etc.
228	510 495 98	8	Scheibe	Washer
229	007 165 98	2	Schelle	Clamp
239	673 312 40	1	Schlauch	Hose assy.
240	621 895 40	1	Schlauchschelle	Hose clip
241	340 509 99	2	Scheibe	Washer
242	509 869 98	2	Mutter	Nut
243	621 008 40	1	Dämmmatte	Insulation