

970-2100b

Seite/Page 1 / 4

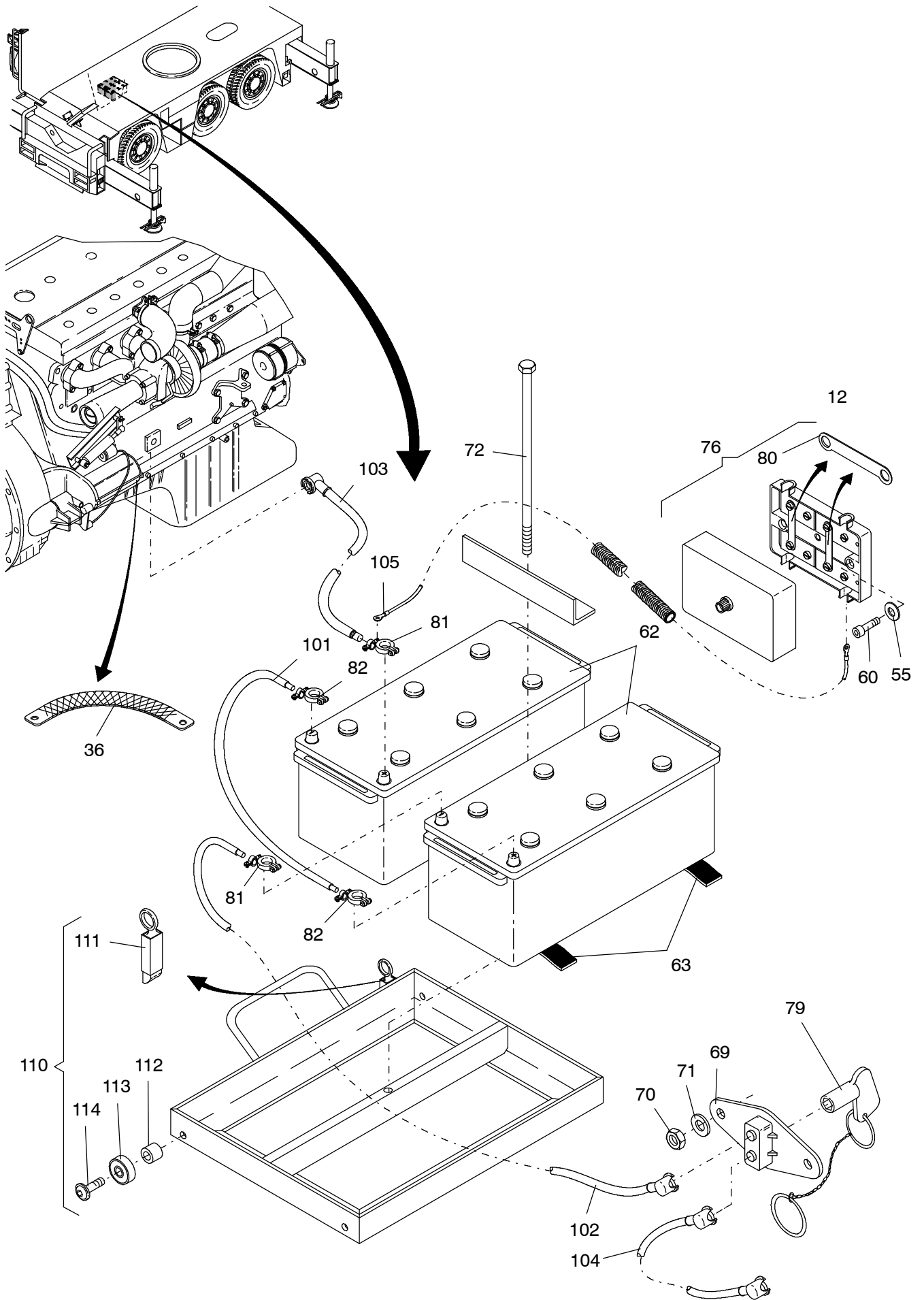

970-2100b

Seite/Page 2 / 4

Bild-Nr Fig Fig Fig Fig Bild nr	ET-Nr Part-No No. de Piece No. de Pieza No. del Pezzo Detalj nr	Stückzahl Qty Qte Ctd Qta Antal		Gegenstand Description Designation Descripcion Designazione Benaemning
08	420 500 12	20	Magnetventil- Kabel mit Stecker	Solenoid valve cable with plug
09	420 470 12	4	Initiatorkabel mit Stecker	Initiator cable with plug
14	348 678 40	1	Dichtung	Gasket
15	056 292 40	30	Kabelband L=186 mm	Cable strap L=186 mm
16	174 411 40	35	Kabelband L=203 mm	Cable strap L=203 mm
17	509 869 98	4	Mutter	Nut
18	509 912 98	4	Schraube	Screw
19	509 858 98	4	Mutter	Nut
36	670 092 40	1	Massekabel Starter	Ground cable starter
37	592 683 40	1	Stiftgehäuse 5-pol.	Pin shell
38	592 290 40	1	Überwurfmutter NW 10	Union nut
39	592 286 40	1	Dichtring NW 10	Seal ring
40	654 687 40	-	Wellrohr NW 10 Länge angeben	Corrugated pipe - state length required
41	551 327 40	5	Stiftkontakt 1,6 1 -1,5 mm ²	Male contact
55	510 321 98	2	Scheibe	Washer
60	509 788 98	2	Schraube	Screw
62	500 308 98	2	Batterie	Battery
63	612 697 40	2	Gummistreifen	Rubber strap
69	621 022 40	1	Batterietrennschalter	Battery switch
70	509 863 98	2	Mutter	Nut
71	510 314 98	2	Scheibe	Washer
72	125 013 99	2	Schraube	Bolt
75	670 447 40	1	Batterieverkabelung, kpl. best. aus Bild-Nr. 81-83	Battery cables consist. of fig-nos: 81-83
76	160 999 40	1	Sicherungsdose	Fuse box
77	529 081 40	1	Temperaturschalter 55 °C s. EL-Blatt 970-1800, etc.	Temperatur 55 °C see page 970-1800, etc.
78	529 083 40	1	Temperaturschalter 85 °C s. EL-Blatt 970-1800, etc.	Temperatur 85 °C see page 970-1800, etc.
79	979 523 73	1	Schlüssel	Key
80	058 077 40	1	Sicherungseinsatz	Fuse cartridge
81	420 246 99	2	Schraubklemme (+)	Clamp
82	420 247 99	2	Schraubklemme (-)	Clamp
83	670 448 40	1	Batterieverkabelung best. aus Bild 101-108	Battery cables consist. of fig. 101-108
91	670 444 40	1	Kabelbaum "UW" siehe EL-Blatt 970-2202, etc.	Harness "chassis" see page 970-2202, etc.
101	471 671 99	-	Kabel	Cable
102	420 263 12	-	Kabel, kpl.	Cable, assy.
103	420 264 12	-	Kabel, kpl.	Cable, assy.

Bild-Nr Fig Fig Fig Fig Bild nr	ET-Nr Part-No No. de Piece No. de Pieza No. del Pezzo Detalj nr	Stückzahl Qty Qte Ctd Qta Antal		Gegenstand Description Designation Descripcion Designazione Benaemning
104	420 265 12	-	Kabel, kpl.	Cable, assy.
105	420 266 12	-	Kabel, kpl.	Cable, assy.
110	305 650 12	1	Batterierahmen, kpl.	Battery frame, assy.
111	421 410 12	1	Verschluß	Fastener
112	421 527 12	4	Distanzbuchse	Distance bushing
113	421 579 12	4	Kugellager	Ball bearing
114	513 957 98	4	Schraube	Screw
115	000 745 12	1	Kabel mit Winkelstecker für Spiegel L=4,0 m	Cable with elbow plug for mirror L=4,0 m
116	592 683 40	1	Stiftgehäuse 5-pol.	Pin shell
117	592 290 40	1	Überwurfmutter NW 10	Union nut
118	592 286 40	1	Dichtring NW 10	Seal ring
119	551 327 40	5	Stiftkontakt 0,5 - 1,0 mm ²	Male contact
121	490 689 40	1	Hängetaster, kpl. siehe EL-Blatt 970-2190	Hanging key button, assy. see page 970-2190