

98-6187a

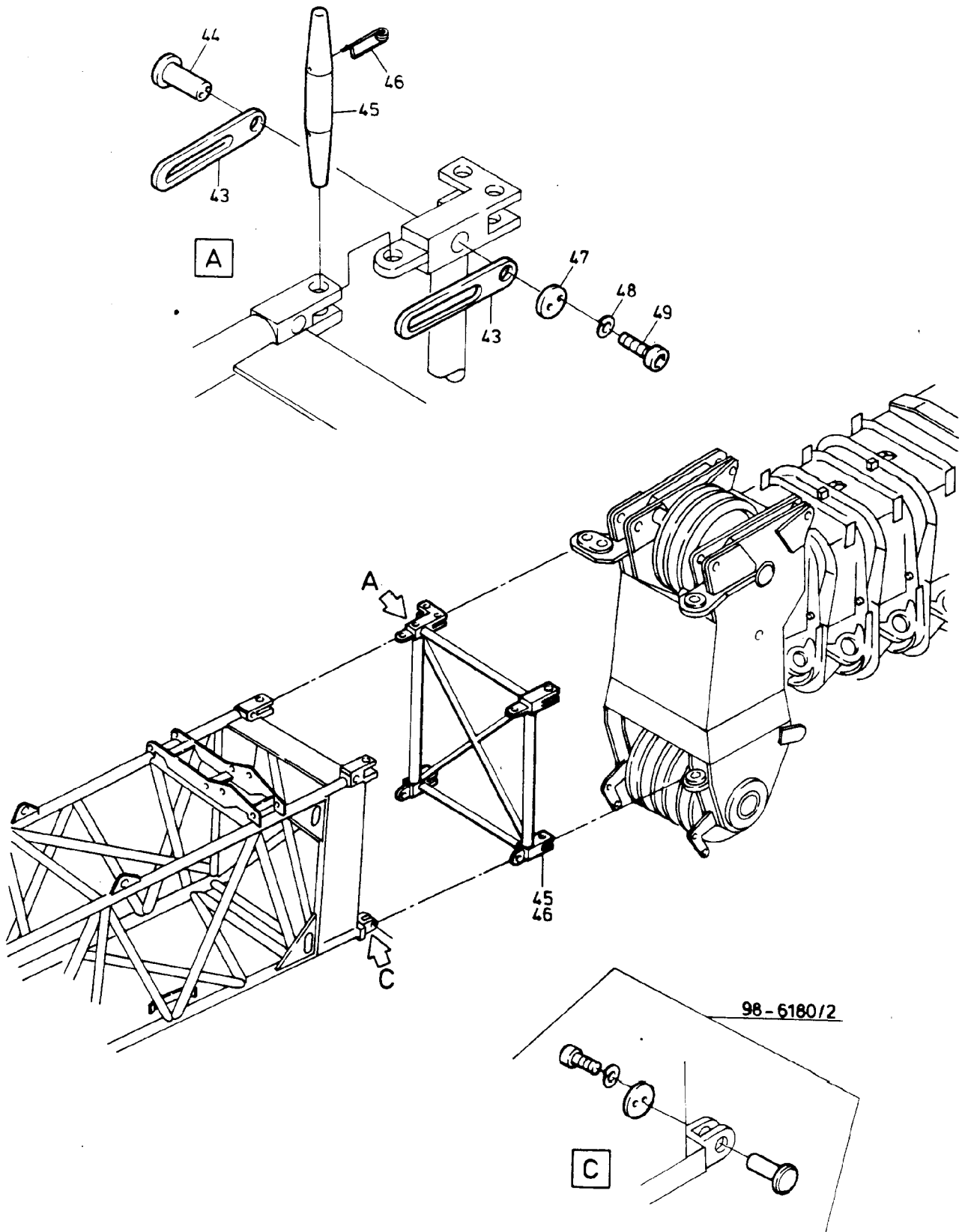

98-6187a

Bild-Nr Fig Fig Fig Fig Bild nr	ET-Nr Part-No No. de Piece No. de Pieza No. del Pezzo Detalj nr	Stückzahl Qty Qte Ctd Qta Antal		Gegenstand Description Designation Descripcion Designazione Benaemning
			Bild 1	Graphic 1
01	461 128 40	1	Kupplungsbolzen ø 22	Pin
02	342 516 99	2	Sicherungsring	Circlip
03	435 047 40	2	Seilrolle ø 80	Sheave
04	435 048 40	1	Rollenhalter	Retainer for roller
05	423 215 40	1	Schiene	Rail
06	423 221 40	1	Schiene	Rail
07	423 385 40	2	Bolzen	Pin
08	001 645 98	4	Sicherungsfeder	Locking spring
09	435 049 40	1	Rollenhalter	Retainer for roller
10	435 051 40	2	Seilbügel	Rope shackle
11	340 470 99	4	Scheibe	Washer
12	342 083 99	2	Splint	Cotter pin
13	394 961 40	1	Seil	Rope
10	423 338 40	2	Lagerbock	Bearing support
11	396 639 40	2	Stützrolle	Roller
12	407 027 40	2	Bolzen	Pin
13	342 530 99	2	Sicherungsring	Circlip
14	423 381 40	2	Schraube	Nut
15	333 263 99	2	Mutter	Nut
16	307 825 99	12	Schraube	Bolt
17	340 469 99	12	Scheibe	Washer
18	407 042 40	12	Leiste	Strip
21	423 229 40	1	Lagerbock	Bearing support
22	407 291 40	1	Bolzen	Pin
23	407 290 40	2	Platte	Plate
24	307 775 99	4	Schraube	Bolt
25	340 465 99	4	Scheibe	Washer
26	423 228 40	1	Lagerbock	Bearing support
27	423 375 40	1	Bolzen	Pin
			Bild 2	Graphic 2
43	423 258 40	4	Lasche für 20° Neigung	Shackle for 20° inclination
44	423 256 40	4	Bolzen	Pin
45	423 255 40	6	Bolzen	Pin
46	001 645 98	12	Sicherungsfeder	Locking spring
47	404 808 40	4	Scheibe	Disk
48	343 856 99	8	Federring	Lock washer
49	320 361 99	8	Schraube	Bolt
Transportstellung / Hauptauslegerverlängerung				98-6187a
Travel Lock / Main Boom Extension				Seite/Page 3/3