

987-2103

Seite/Page 1 / 3

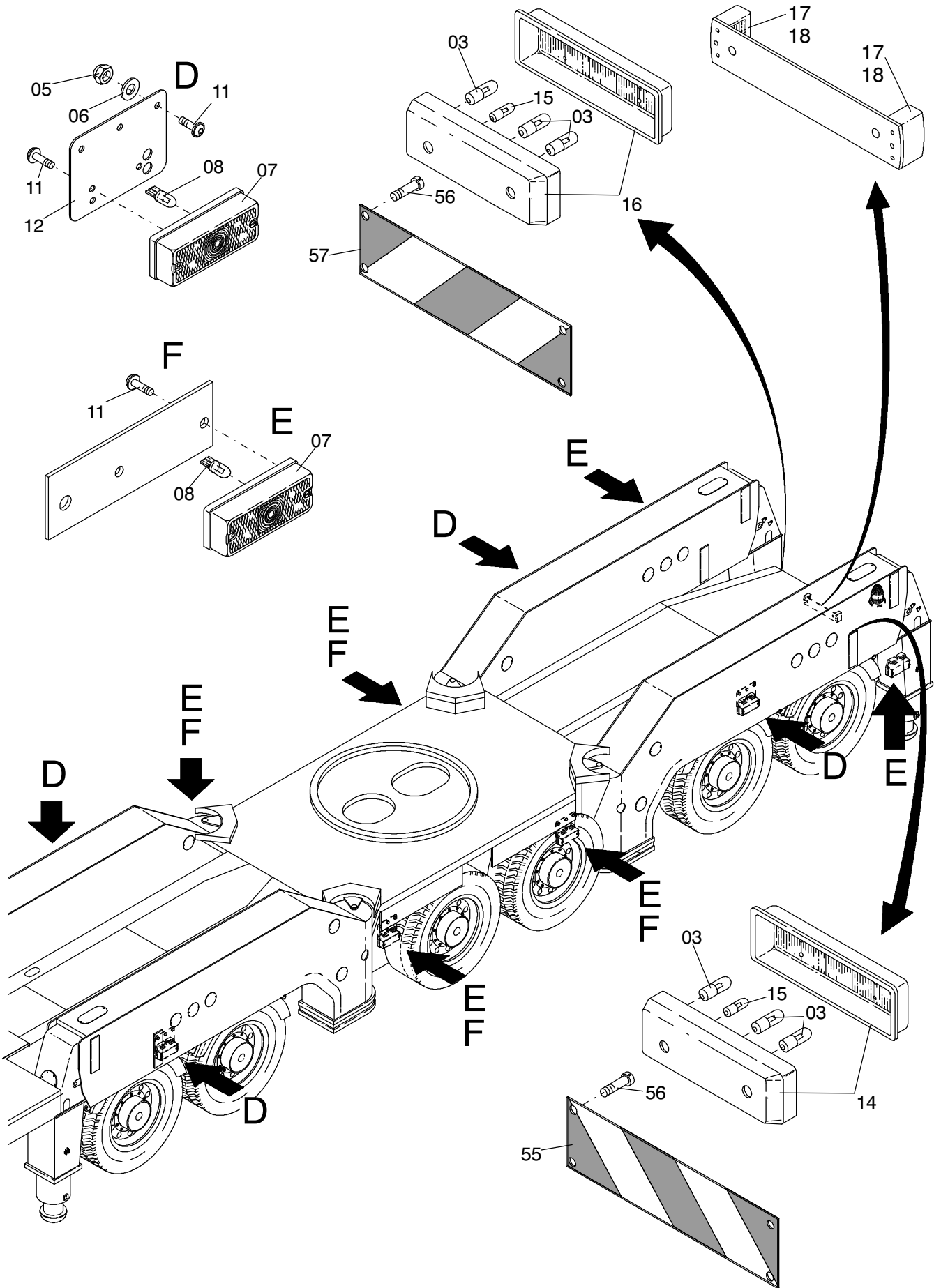

987-2103

Seite/Page 2 / 3

Bild-Nr Fig Fig Fig Fig Bild nr	ET-Nr Part-No No. de Piece No. de Pieza No. del Pezzo Detalj nr	Stückzahl Qty Qte Ctd Qta Antal		Gegenstand Description Designation Descripción Designazione Benaemning
01	576 208 40	2	Rundumleuchte best. aus Bild 111-114	Rotaflare light consist of fig-no. 111-114
02	440 850 40	1	Blinkleuchte links	Traffic light
03	507 374 99	12	Lampe	Lamp
04	320 817 99	16	Schraube	Screw
05	332 101 99	36	Mutter	Nut
06	340 505 99	44	Scheibe	Washer
07	655 000 40	16	Seitenmarkierungsleuchte	Side marker reflector light
08	507 377 99	16	Lampe	Lamp
09	875 280 40	4	Winkel	Angle
10	244 925 40	4	Pendelhalter	Pendulum bracket
11	321 009 99	28	Schraube	Screw
12	889 458 40	8	Halter	Retainer
13	440 851 40	1	Blinkleuchte rechts	Traffic light right
14	621 561 40	1	Heckleuchte links	Tail lamp
15	507 375 99	2	Lampe	Lamp
16	621 562 40	1	Heckleuchte rechts	Tail lamp
17	461 257 40	2	Kennzeichenleuchte	Plate light
18	507 372 99	2	Lampe	Lamp
19	551 253 40	4	Aufnahmeteil	Retain
20	320 316 99	8	Schraube	Screw
21	509 869 98	8	Mutter	Nut
22	340 506 99	8	Scheibe	Washer
23	551 251 40	2	Blinker	Flasher
24	501 408 98	2	Lampe	Lamp
25	551 252 40	2	Fernscheinwerfer	Upper beam
26	507 383 99	2	Lampe	Lamp
27	663 841 40	2	Leuchenträger	Lamp carrier
55	551 055 40	1	Heckmarkierungstafel	Tail marker board
56	320 817 99	8	Schraube	Screw
57	551 056 40	1	Heckmarkierungstafel	Tail marker board
100	551 250 40	2	Abblendscheinwerfer	Lower beam
111	507 383 99	1	Glühbirne	Bulb
112	978 062 73	1	Lichthaube	Push hood
113	978 063 73	1	Gehäusesockel	Housing base
114	978 064 73	1	Motor mit Reflektor	Motor with reflector