

**989-2100**

Seite/Page 1 / 4

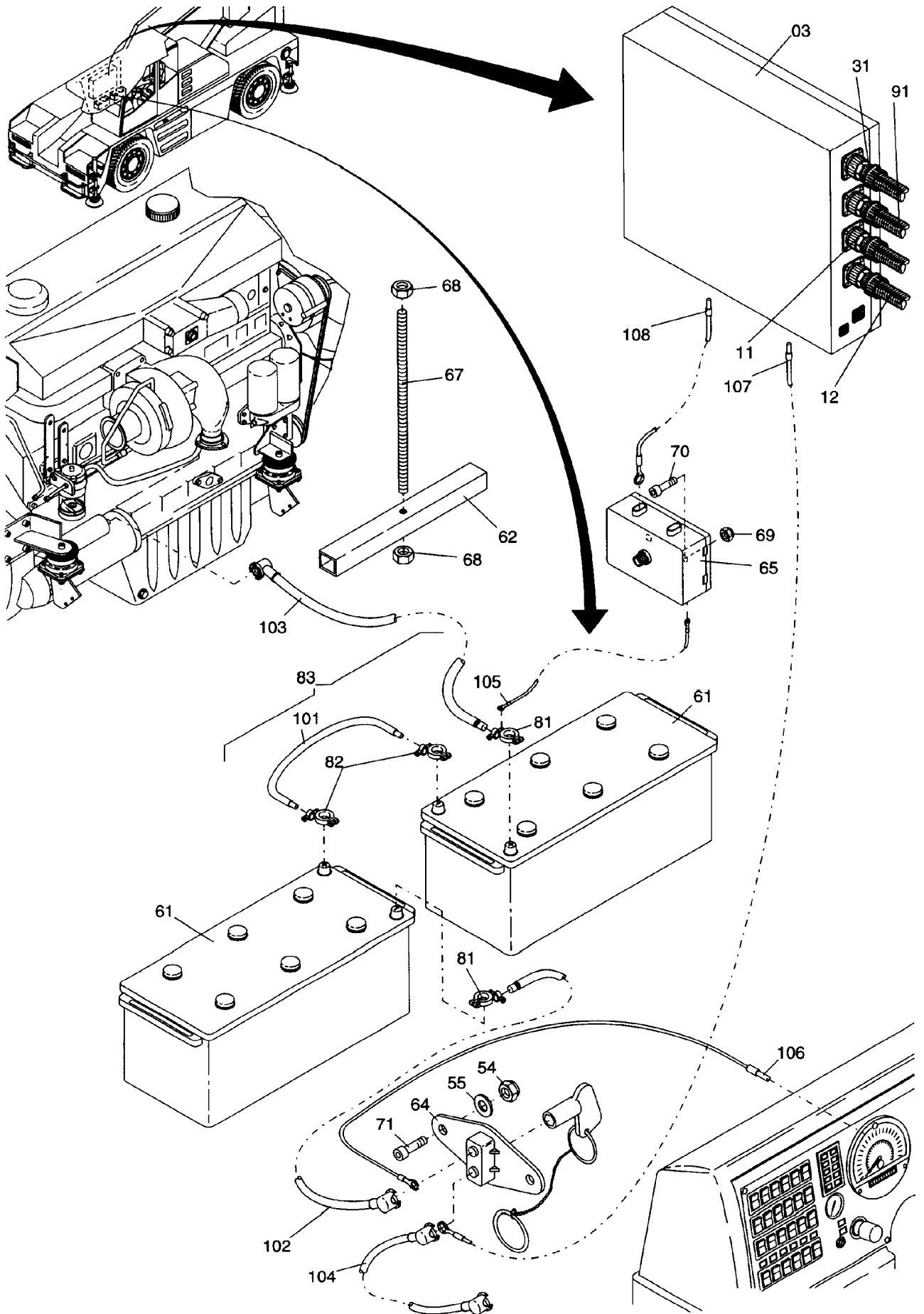

**989-2100**

Seite/Page 2 / 4

Bild-Nr Fig Fig Fig Fig Bild nr	ET-Nr Part-No No. de Piece No. de Pieza No. del Pezzo Detalj nr	Stückzahl Qty Qte Ctd Qta Antal		Gegenstand Description Designation Descripcion Designazione Benaemning
01	-	-	s. EL-Blatt "Beleuchtung"	See page "lighting equipment"
03	-	-	"Zentralelektrik"	"Main electric"
			s. EL-Blatt 989-2115	see page 989-2115
04	-	-	"Bedienkasten Abstützung"	"Operation box outriggers"
			s. EL-Blatt 907-2116, etc.	see page 907-2116, etc.
11	-	1	Kabelbaum "Ventilblock"	Harness "valve block"
			s. EL-Blatt 989-2210, etc.	see page 989-2210, etc.
12	-	1	Kabelbaum, "vorne"	Harness "front"
			s. EL-Blatt 989-2205, etc.	see page 989-2205, etc.
13	348 698 40	20	Magnetventil-Stecker	Solenoid valve plug
14	348 678 40	20	Dichtung	Gasket
15	056 292 40	30	Kabelband L=186 mm	Cable strap
16	174 411 40	35	Kabelband L=203 mm	Cable strap
17	509 869 98	4	Mutter	Nut
18	509 912 98	4	Zylinderschraube	Screw
19	509 858 98	4	Mutter	Nut
31	-	1	Kabelbaum Motor	Harness engine
			siehe EL-BLatt 989-2220, etc.	see page 989-2220, etc.
32	256 075 40	1	Geber Motoröldruck	Transmitter, engine-oil pressure
36	670 092 40	1	Massekabel Starter	Ground cable starter
37	592 683 40	1	Stiftgehäuse 5-pol.	Pin shell
38	592 290 40	1	Überwurfmutter NW 10	Union nut
39	592 286 40	1	Dichtring NW 10	Seal ring
40	*	-	Wellrohr NW 10	Corrugated pipe
41	551 327 40	5	Stiftkontakt 1,6 1 -1,5 mm <sup>2</sup>	Male contact
54	509 869 98	11	Mutter	Nut
55	340 506 99	13	Scheibe	Washer
61	500 308 98	2	Batterie	Battery
62	546 530 40	1	Batteriehalter	Battery bracket
63	670 073 40	1	Batterieverkabelung, kpl. best. aus Bild-Nr. 81-83	Battery cables consist. of fig-nos: 81-83
64	621 022 40	1	Batterietrennschalter	Battery switch
65	160 999 40	1	Sicherungsdose	Fuse box
66	546 506 40	1	Gummiunterlage	Rubber plate
67	546 546 40	-	Gewindestange	Threaded rod
68	509 862 98	2	Mutter	Nut
69	510 875 98	2	Mutter	Nut
70	509 772 98	2	Zylinderschraube	Screw
71	510 523 98	2	Zylinderschraube	Screw
80	058 077 40	1	Sicherungseinsatz, 50A	Fuse, 50A
81	420 246 99	2	Schraubklemme (+)	Clamp

<b>Bild-Nr</b> Fig Fig Fig Fig Bild nr	<b>ET-Nr</b> Part-No No. de Piece No. de Pieza No. del Pezzo Detalj nr	<b>Stückzahl</b> Qty Qte Ctd Qta Antal		<b>Gegenstand</b> Description Designation Descripcion Designazione Benaemning
82	420 247 99	2	Schraubeklemme (-)	Clamp
83	670 093 40	1	Batterieverkabelung, kpl. best. aus Bild 101-108	Battery cables, assy. consist. of fig. no 101-108
91	-	1	Kabelbaum UW s. EL-Blatt 989-2202, etc.	Harness chassis see page 989-2202, etc.
101		-	Kabel	Cable
102	420 263 12	-	Kabel, kpl.	Cable, assy.
103	420 264 12	-	Kabel, kpl.	Cable, assy.
104	420 265 12	-	Kabel, kpl.	Cable, assy.
105	420 266 12	-	Kabel, kpl.	Cable, assy.
106	420 267 12	-	Kabel, kpl.	Cable, assy.
107	420 268 12	-	Kabel, kpl.	Cable, assy.
108	420 269 12	-	Kabel, kpl.	Cable, assy.
			* Meterware, bei Bestellung Länge angeben	* Bulk ware, state length required
*	654 687 40	-	Wellrohr NW 10	Corrugated pipe